



Assembly Manual



Table of contents

◆	Table of contents	2
◆	Regulations	3
◆	Panel preparation	4
	Panel 1	5
	Panel 2 / 3	6
◆	Installation of guide rails	7
◆	Installation of the lifting drive	8
◆	Connection of the control unit	9
◆	Installation of lower panel	11
◆	Installation of the belts	13
◆	Operation in 'SLOW' mode	15
◆	Installation second / third panel	16
◆	Adjustment of the guide blocks	18
◆	Putting the system into operation	20
◆	Installation of the fixed panel	21
◆	Installation of the door aligners	23
◆	Connection of the relay contact	24

Regulations

Liability

To ensure correct operation of the Assunta system, all steps in this manual must be followed carefully. VANBOT BV can never be liable for the use of this manual and shall not be responsible for incorrectly installed systems.

Guidelines

It is essential that the panels are straight. Therefore, a maximum curvature or torsion of 1.5 mm applies to all the panels of the system.

Copyright

All rights reserved. Nothing in this publication may be copied, stored in an automated data file or made public, in any way or form, be it electronic, mechanical, by means of photocopies, recordings or any other method without prior written permission from the publisher. © 2025, VANBOT BV. This manual is self-published.

Opbouw panelen

True-to-scale drawings can be downloaded from the website www.assunta.be.

Mill the panels and, if applicable, the side guide rails according to the drawings from www.assunta.be. Also drill all the holes..

Lower panel:



Optional second panel:



Optional third panel:



Fixed panel:



Guide rail:



Configurator

Choose between:



Dimensions

Number of moving panels:

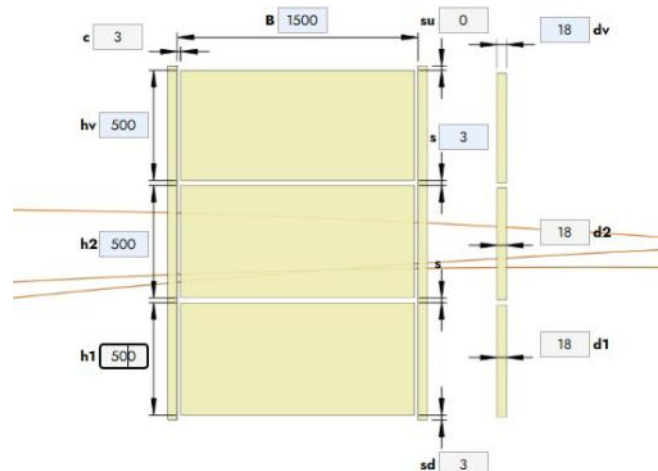

- Side guide rails visible from the front
- Side guide rails front covered
- Surface Mounted

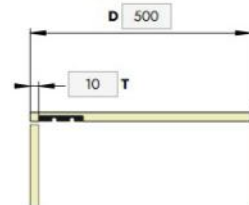

Specific weight of material: 750 kg/m³ MDF Standard

Weight of moving panels: 20.2 kg

Minimum depth D required: 256.0 mm

Drawings based on dimensions

Choice PDF or DXF

PDF with dimensions

AutoCAD DXF

Panel 1

Mount the frames (left and right) for the lower panel on the panel.

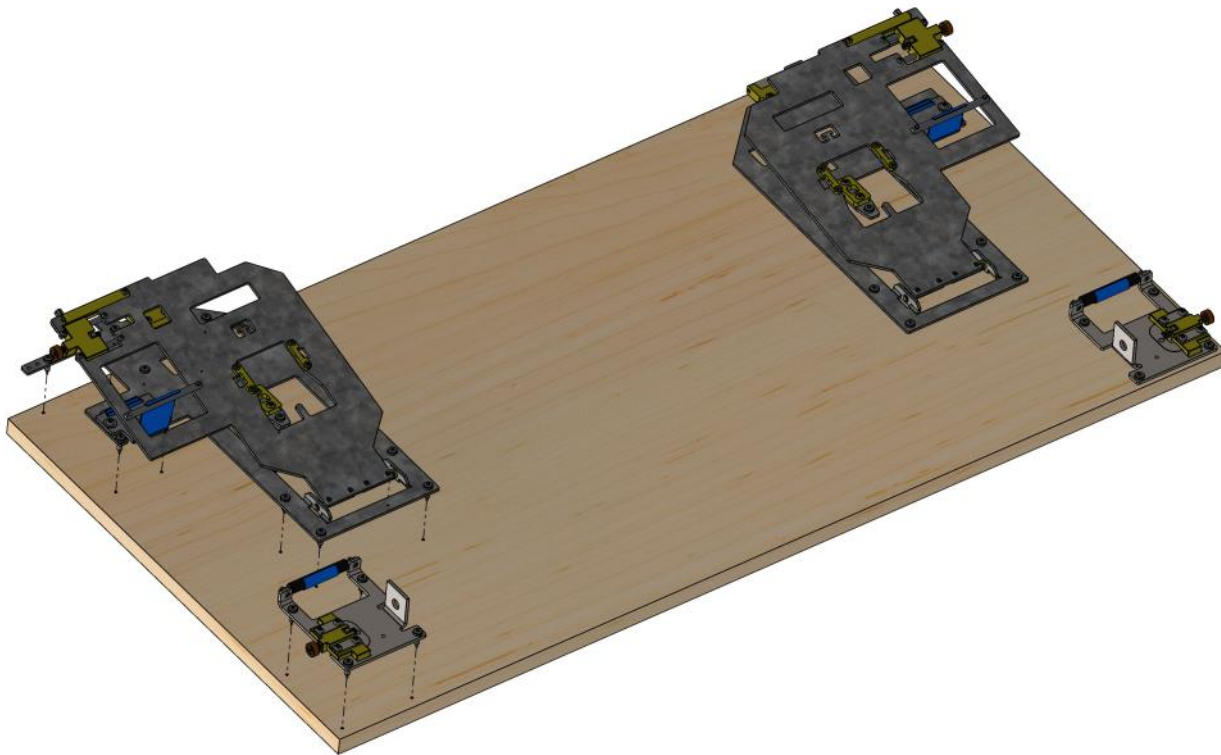

For **surface mounted panels**, provide the separately available 6 mm intermediate plate.

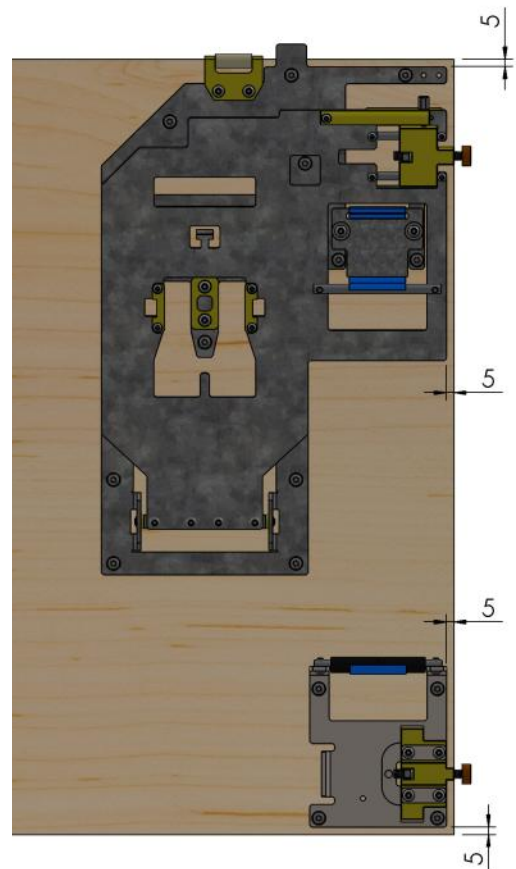
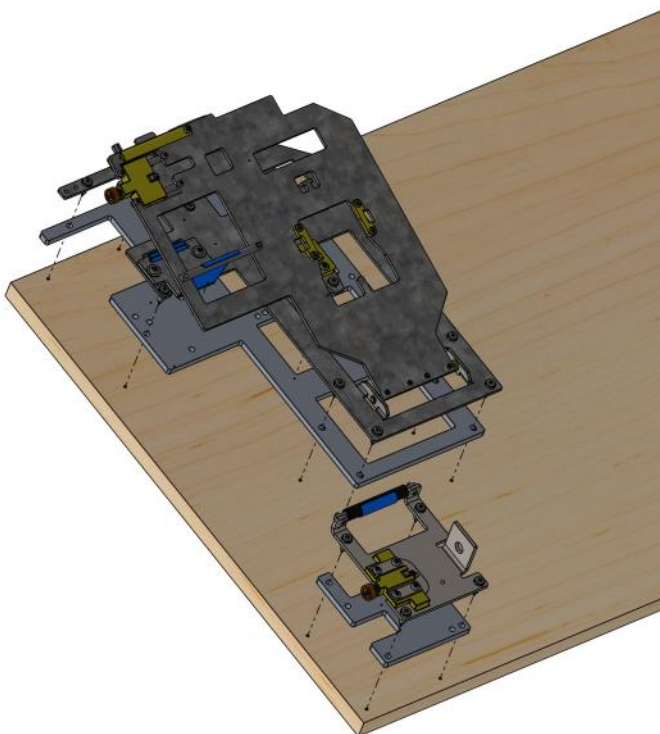

Panel 2 / 3 (if applicable)

Mount the frames (left and right) for the third panel on the panel..

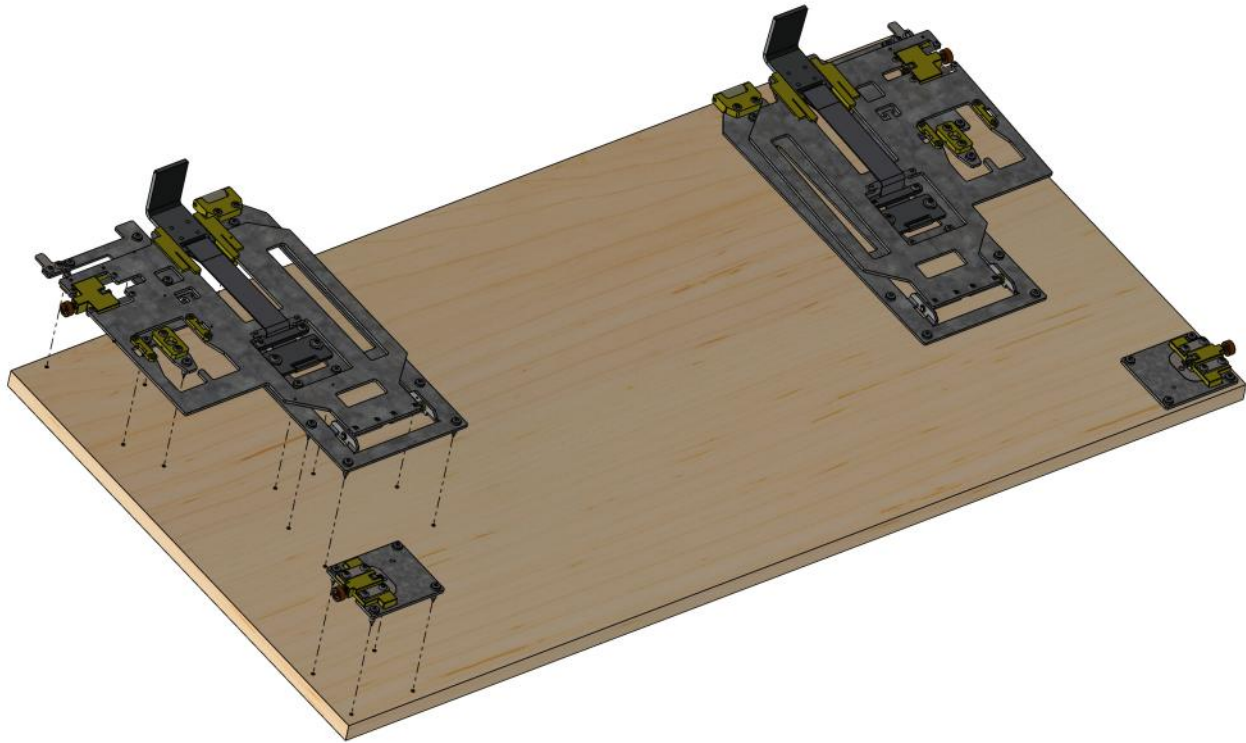

For **surface mounted panels**, provide the separately available 6 mm intermediate plate.

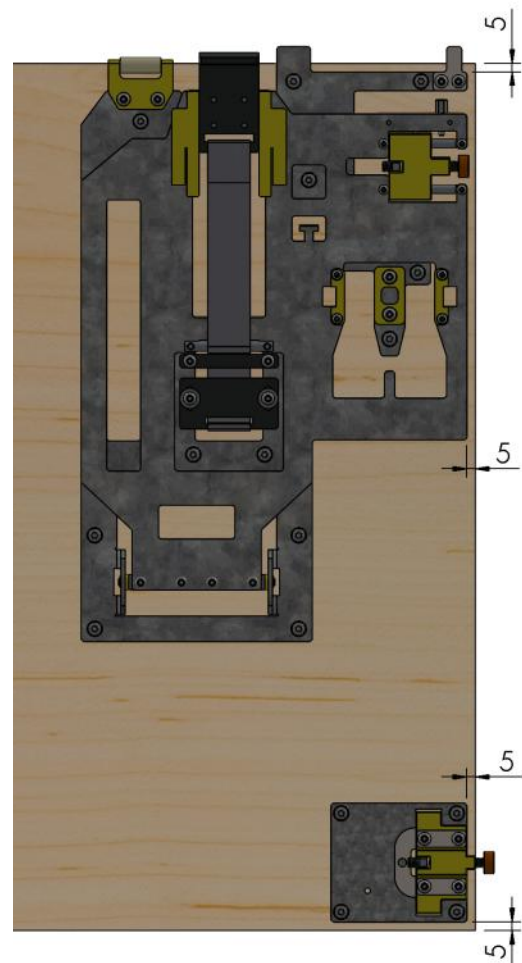
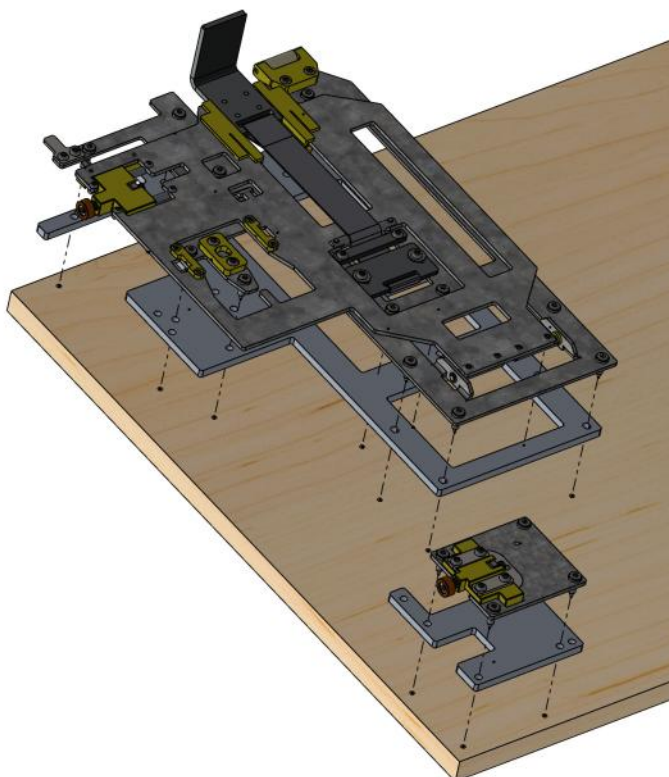

Installation of the guide rails

Place the side guides in the side walls of you cupboard. If these were purchased, there is an excess of 35 mm on the height. Cut these to size at the top.

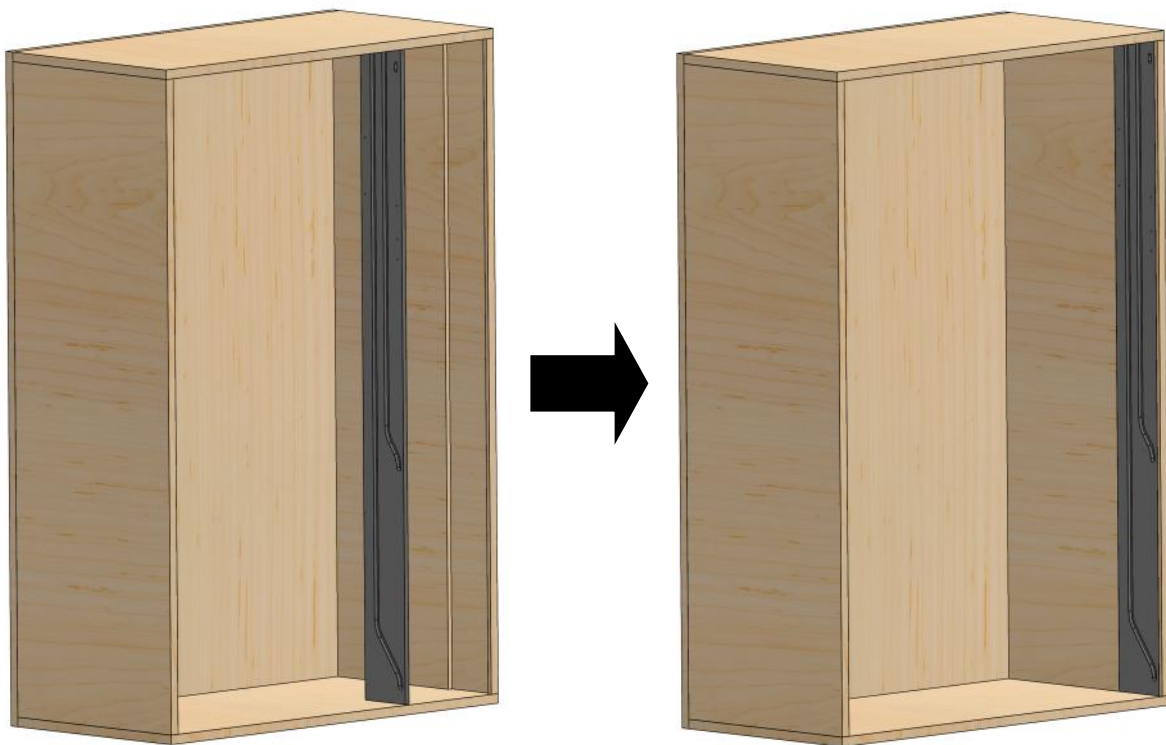

Installation of the lifting drive

Place the lifting drives in the cabinet. If the side guides were purchased, the front $\varnothing 3.5$ mm holes are already pre-drilled on the side guides.



The height dimension for the lower bore is shown on the drawings available at www.assunta.be. The side dimension is fixed relative to the side guide.

Connection of the control unit

Place the control box in the cabinet (between the motors). Connect the power cable 220V and motor cables to the control box. Optionally, also connect the remote control receiver and/or cable (Assunta or own) push buttons.

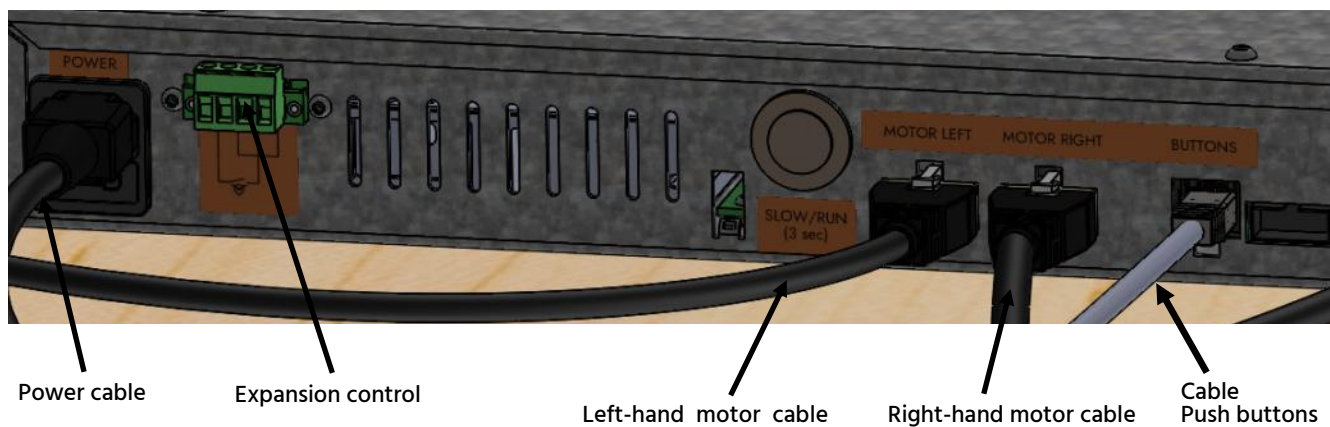
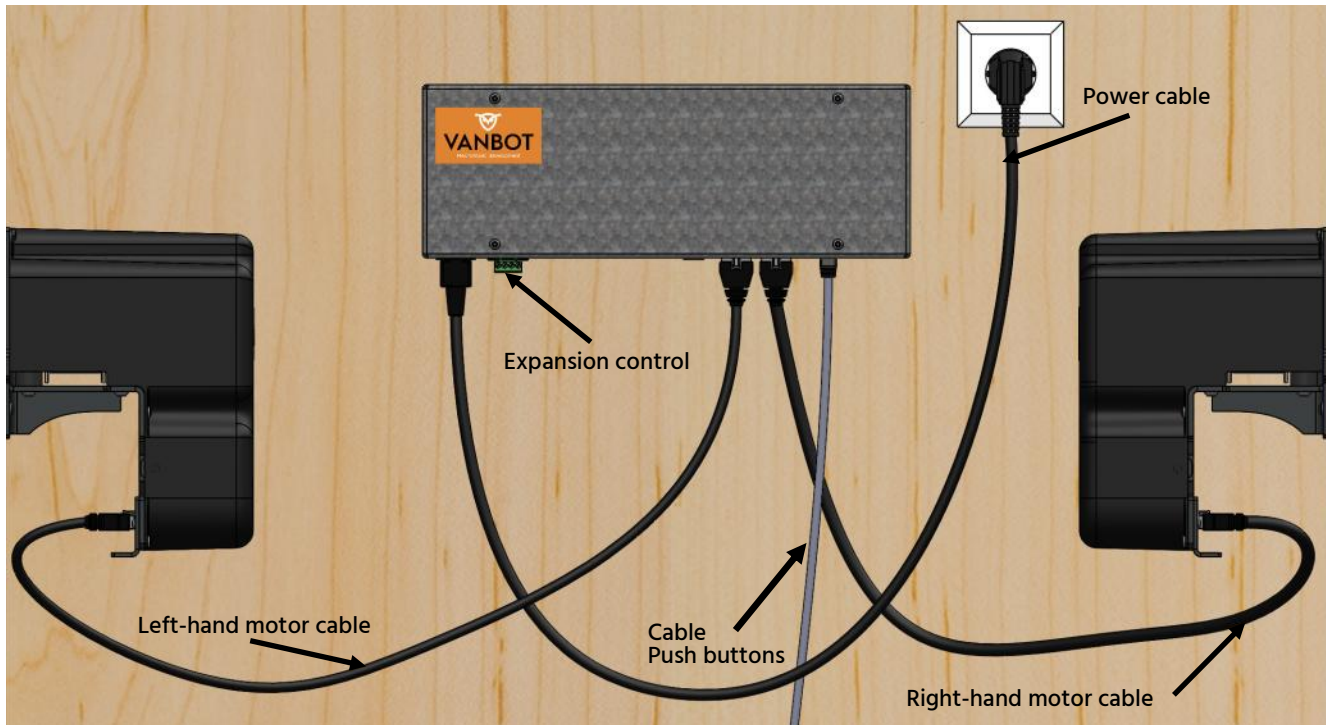

Also connect the motor cables on the motor side.



To connect (your own) push buttons or home automation, you will need the button cable. This cable has 3 open threaded ends, one for the upward movement (blue/white), one for the downward movement (brown), and the outgoing voltage (blue). (No external power supply is therefore required.)

Connect the RJ45 plug to the control cabinet. It must be plugged into the 'Buttons' socket.

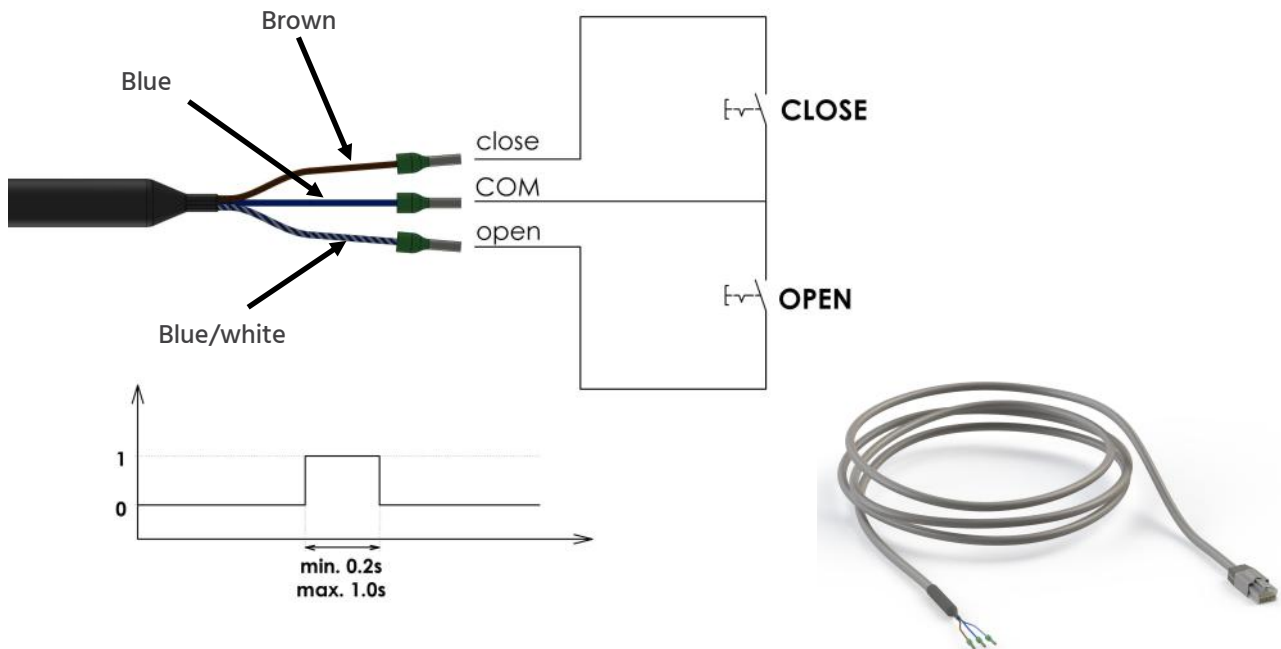

Proceed as follows to install any Assunta push buttons. Mill a recess according to the drawing below and glue the buttons in. Connect the RJ45 plug to the control cabinet. It must be plugged into the 'Buttons' socket.



Installation lower panel

On both the left and right sides of the panel, unscrew (not completely!) the adjustment bolt of the top and guide wheels.

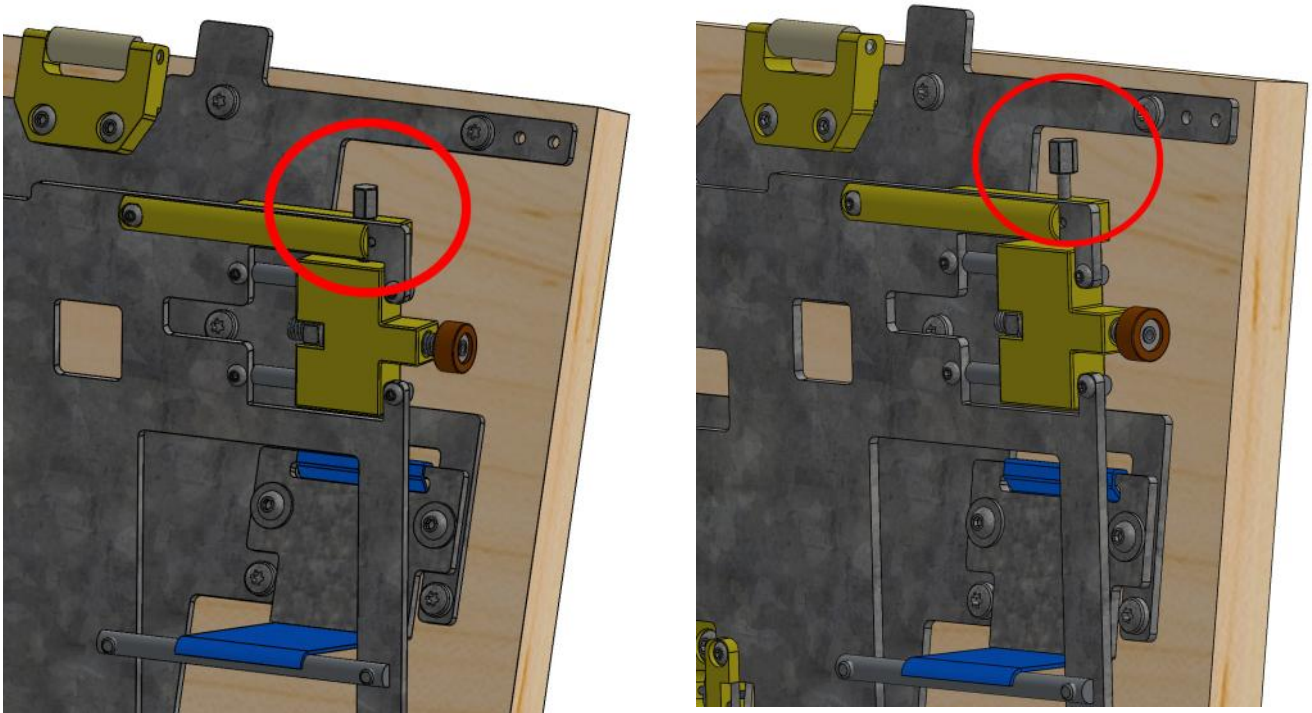

Slide the carriage of the guide block inwards.

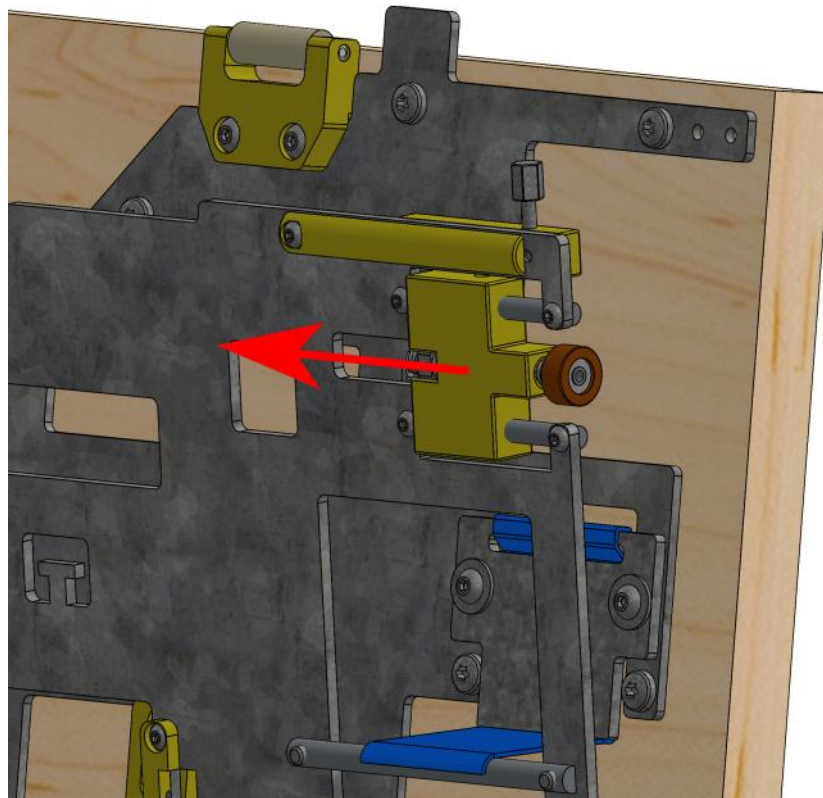

Insert the panel with the top wheels retracted into the corpus in such a way that the lower wheels enter the corresponding slot.



Bring the upper wheel to the level of the slot, slide the wheel into the slot and retighten the adjustment bolt.

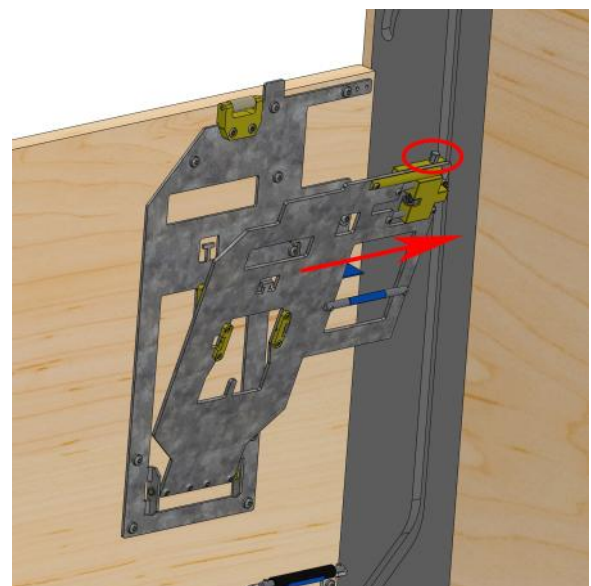
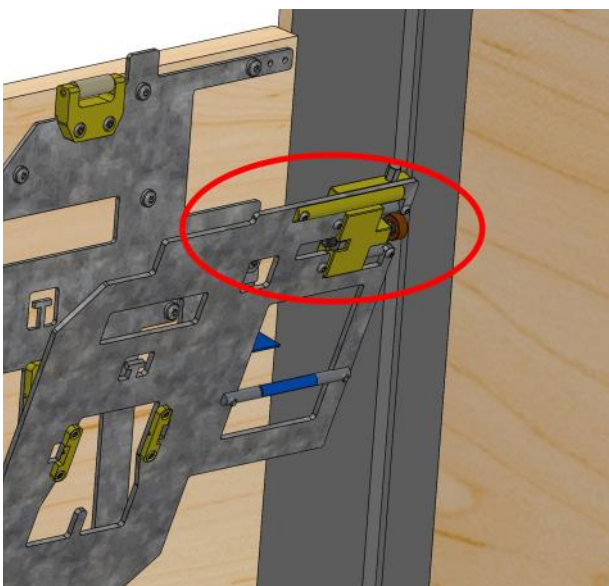

Installation of the belts (on the lower panel)

Set the system to "SLOW" mode.

This can be done in three different ways:

1. Using the push buttons (your own or Vanbot): press both buttons simultaneously for three seconds and release when you hear a single beep.
2. Using the push buttons on the remote control: press them together and release them after 3 seconds when you hear the next beep. This does not always work and can be quite difficult with some remote controls.
3. Using the SLOW/RUN button on the control box: press and hold for 3 seconds and release when you hear the next beep.

The control is in "SLOW" mode if you hear a beep each time you press a button.

Mode SLOW



Push buttons

or



Remote Control

or

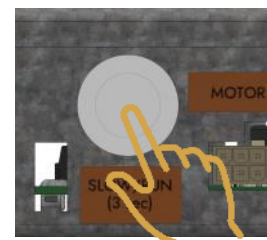

Control box

Lower the belts sufficiently by pressing and holding the CLOSE button on the push buttons or the remote control. When you release the button, the movement stops. Simply resume by pressing again. Run the motors until the belt clamps can be attached to the bottom panel.



Push buttons

or

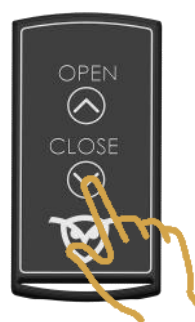

Remote Control

Screw the end plate of the belts onto the panel. Note well the assembly.

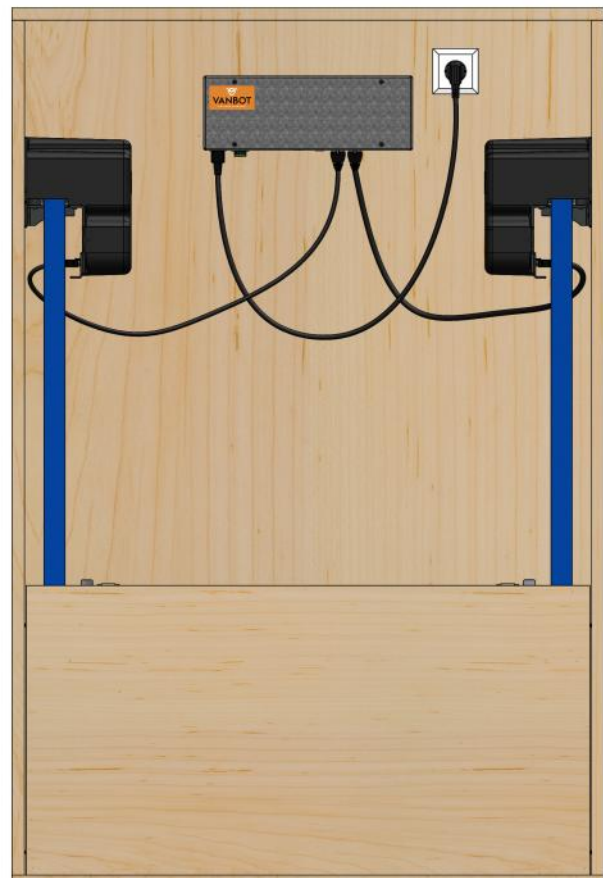
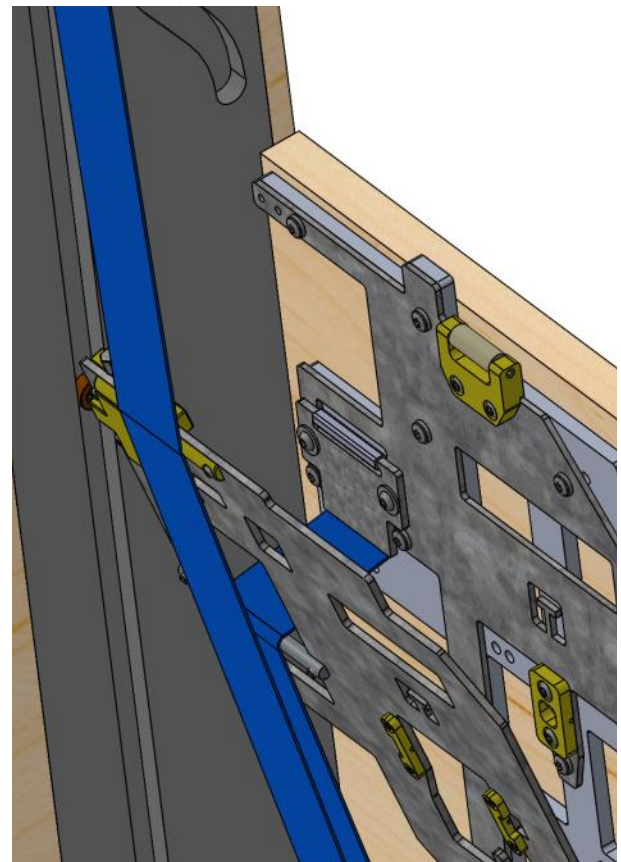
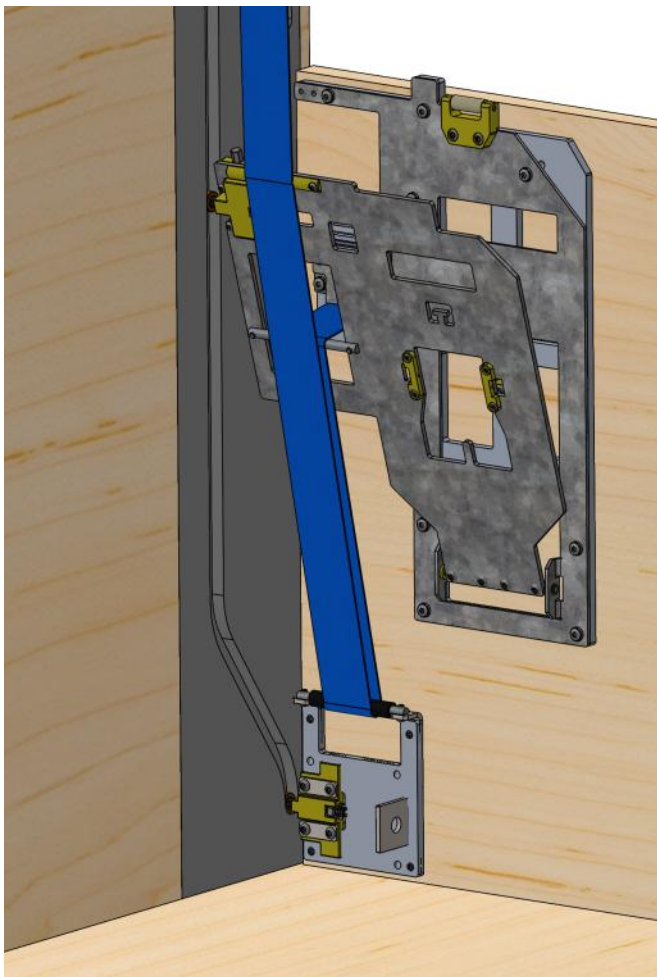

Operation in 'SLOW' mode

When you press the CLOSE button on the push buttons or the remote control (you will hear a beep each time), both belts will lower as long as the button is pressed. When you release the button, the movement will stop.

CLOSE



Push buttons

or



Remote Control

When you press the OPEN button on the push buttons or the remote control (you will hear a beep each time), the belts will move upwards as long as the button is pressed. When you release the button, the movement will stop. If only one belt is tensioned and the other belt is loose, the loose belt will first pull up until it is tensioned. This means that after initial installation, the belts first tighten before pulling up the door.

If two belts are loose, you can always move one belt by holding the other belt taut by hand.

OPEN



Push buttons

or



Remote Control

Installation second / third panel

On both the left and right sides of the panel, unscrew (not completely!) the adjustment bolt of the top and guide wheels.

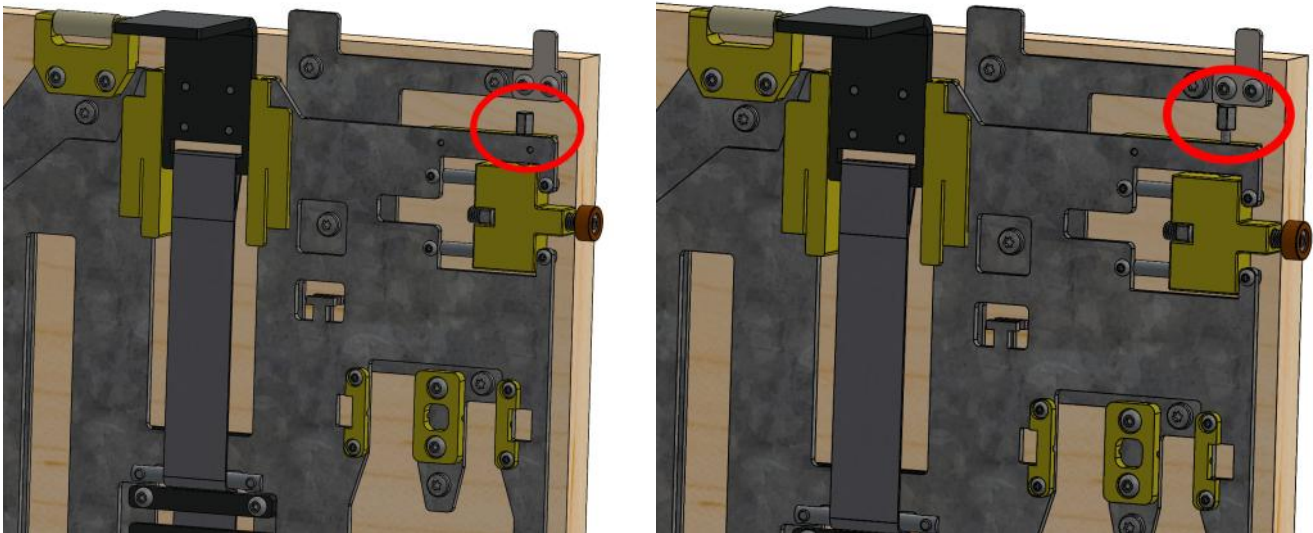

Slide the carriage of the guide block inwards.

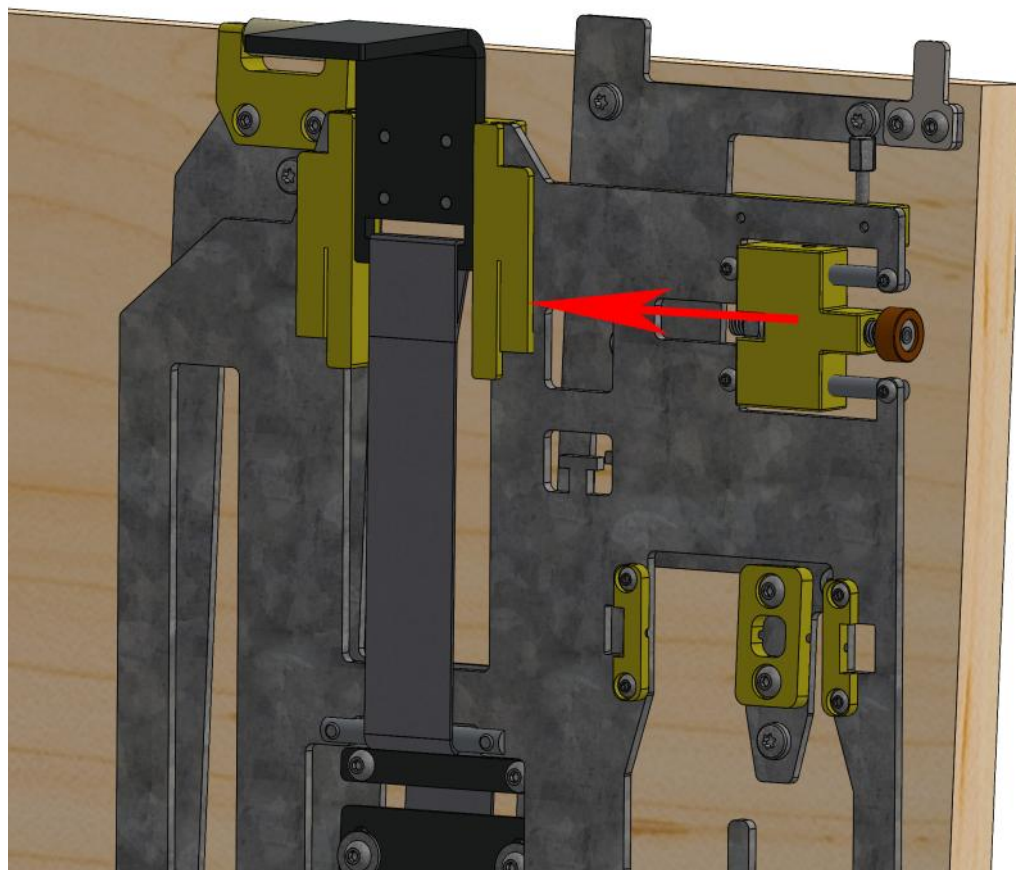

Insert the panel with the top wheels retracted into the corpus in such a way that the lower wheels enter the corresponding slot.



Bring the upper wheel to the level of the slot, slide the wheel into the slot and retighten the adjustment bolt.

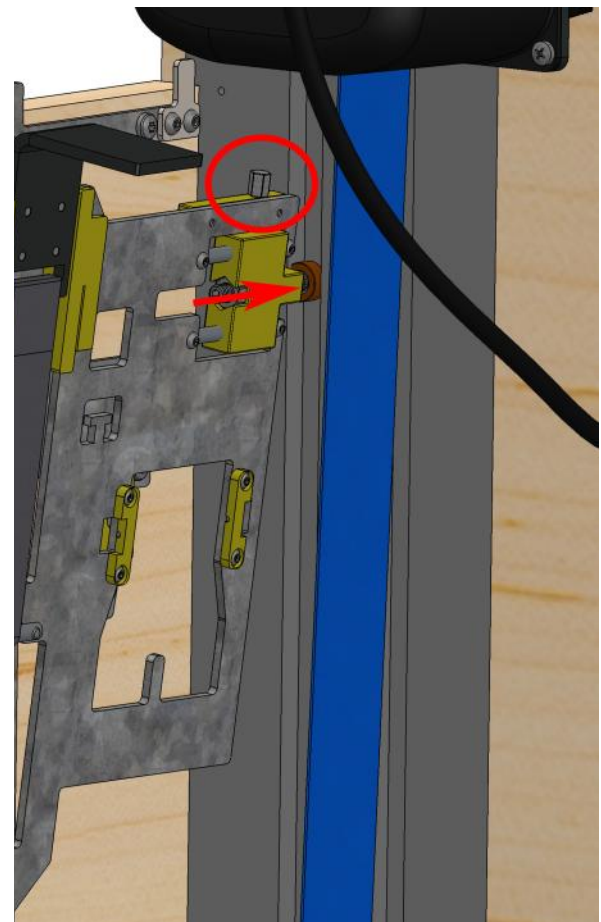
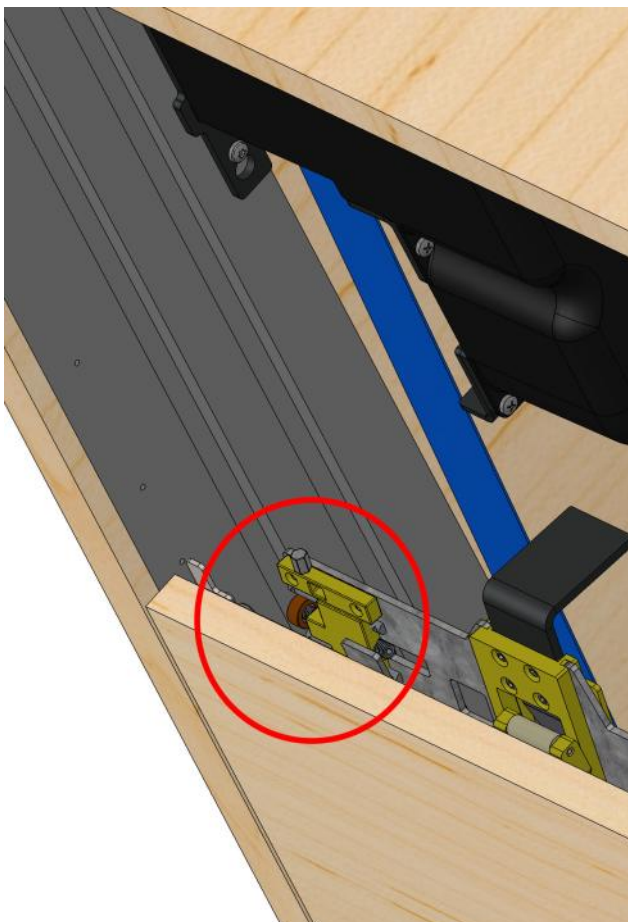

Adjustment of the guide blocks

Depth control upper guide blocks.

Adjust the depth of the wheel in the slot by using an Allen key SW 3 to reduce or increase the depth of the wheel in the slot. Adjust so that on both sides you have adjusted the wheel to within 0.5 mm of the bottom of the slot.

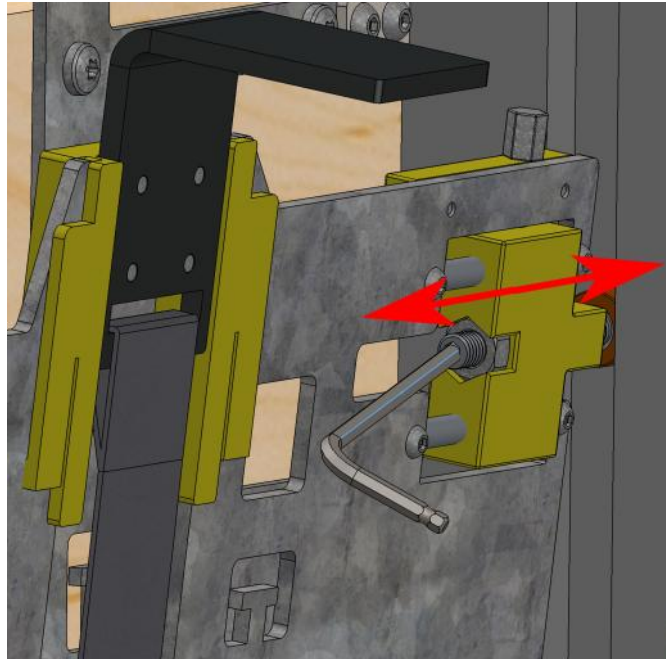

Depth control lower guide blocks.

The arrangement is identical to the upper guide wheels.

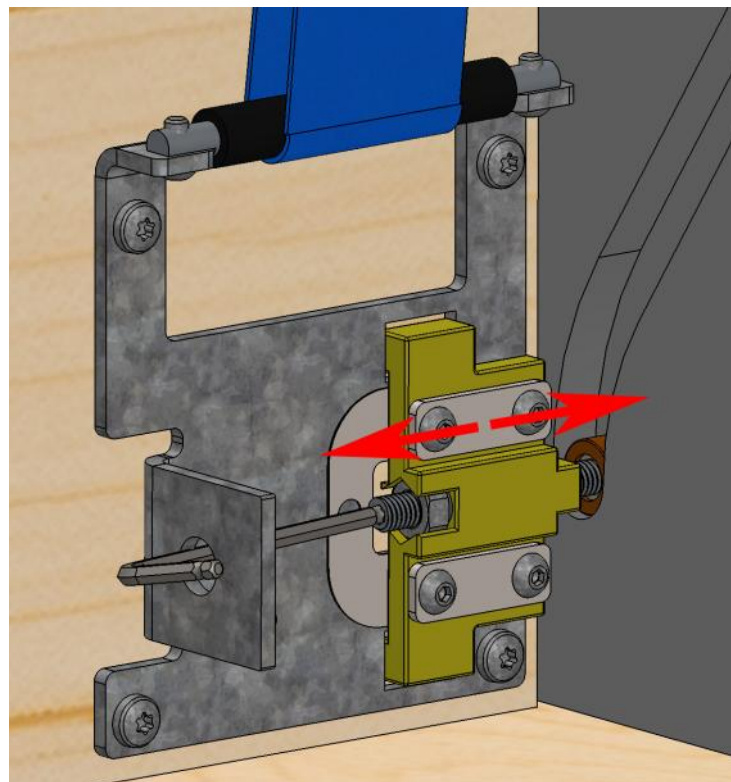

Height control lower guide blocks.

The height of the guide blocks on the panel can be adjusted by loosening the 4 fixing bolts with Allen key SW 2.5. After moving the block up or down, retighten the bolts.

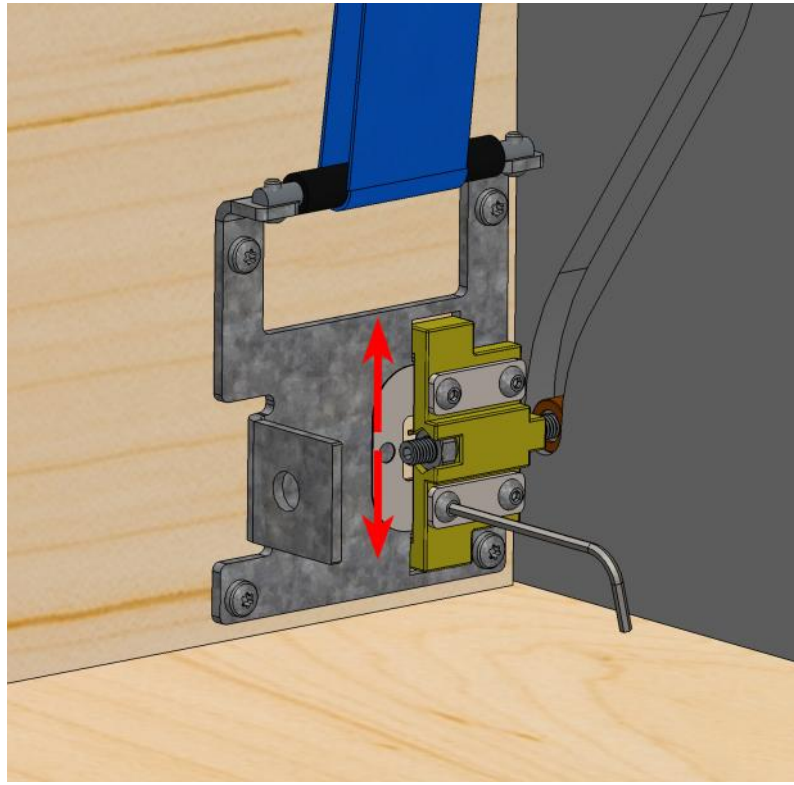
**Front control lower guide blocks.**

By placing the thickness plates of 0.2 mm in front of guide block, the position of the guide block relative to the front of the panel can be changed.

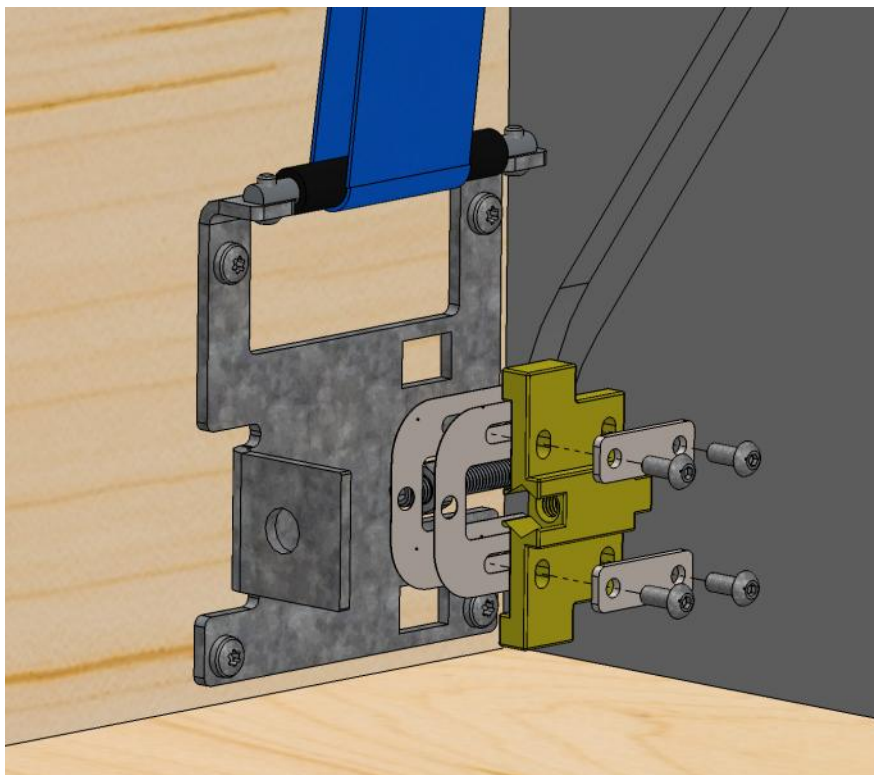

Putting the system into operation

Once the panels are correctly positioned and the system is running smoothly in "SLOW" mode, you can initialise the control system by switching to "RUN" mode.

There are three ways to do this:

1. Using the push buttons (your own or Vanbot): press both buttons simultaneously for 3 seconds and release when you hear two beeps.
2. Using the push buttons on the remote control: press them simultaneously and release them after 3 seconds when you hear the next two beeps. This does not always work and can be quite difficult with some remote controls.
3. Using the SLOW/RUN button on the control box: press and hold for 3 seconds and release when you hear

Mode RUN



Push buttons

or



Remote Control

or

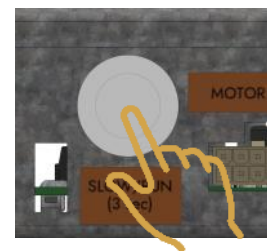

Control box

The panels now first move downwards, adjust themselves and then move upwards. Once at the top, the system is ready for use. Initialisation is fully automatic. NO interaction is required. After initialisation, the panels move up and down quickly when the push buttons or remote control are operated.

CLOSE



Push buttons

or

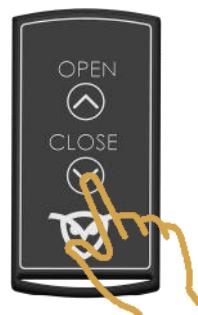

Remote Control

OPEN



Push buttons

or



Remote Control

Installation of fixed panel

Mount all components on the fixed panel, at the bottom the ball snappers and at the top the hinge blocks.



For **surface mounted** panels, provide the separately available 6 mm intermediate plate.

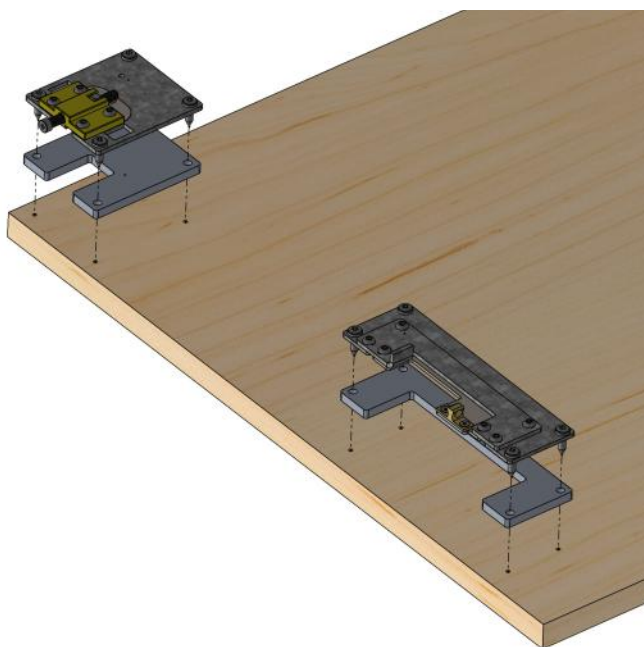

Screw the ball snappers to the side guides. Notice the adjustability in height and depth.

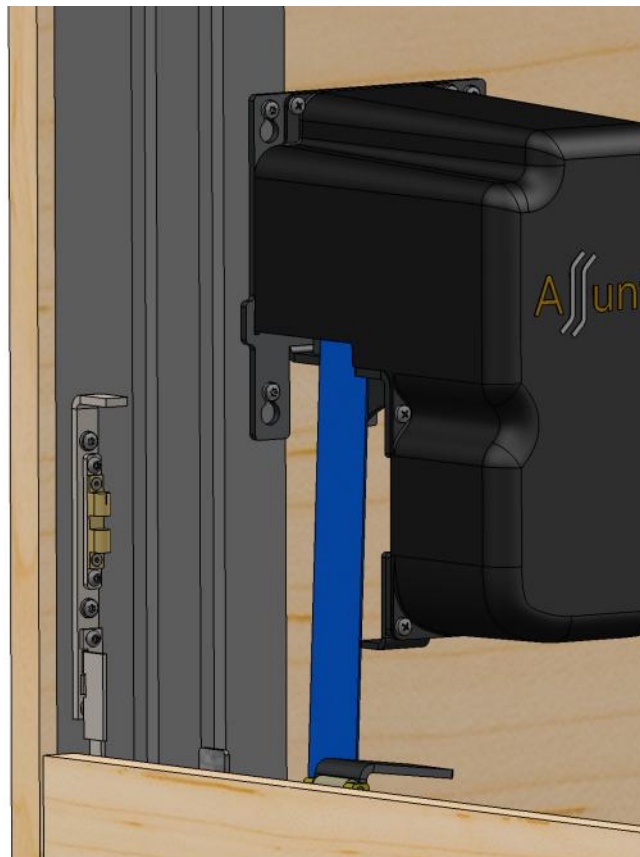

Place the fixed panel in the cabinet and unscrew the wheel of the hinge blocks into the groove provided for this purpose. Make sure the vertical clearance around the panel is evenly distributed.



Installation of the door aligners (optional)

Cut the threaded rod of the door aligners to a length such that the position is well over half the 35 mm recess. On one side, screw the hex nut and 2 washers over the threaded rod. On the other side, screw the square nut over the threaded rod.

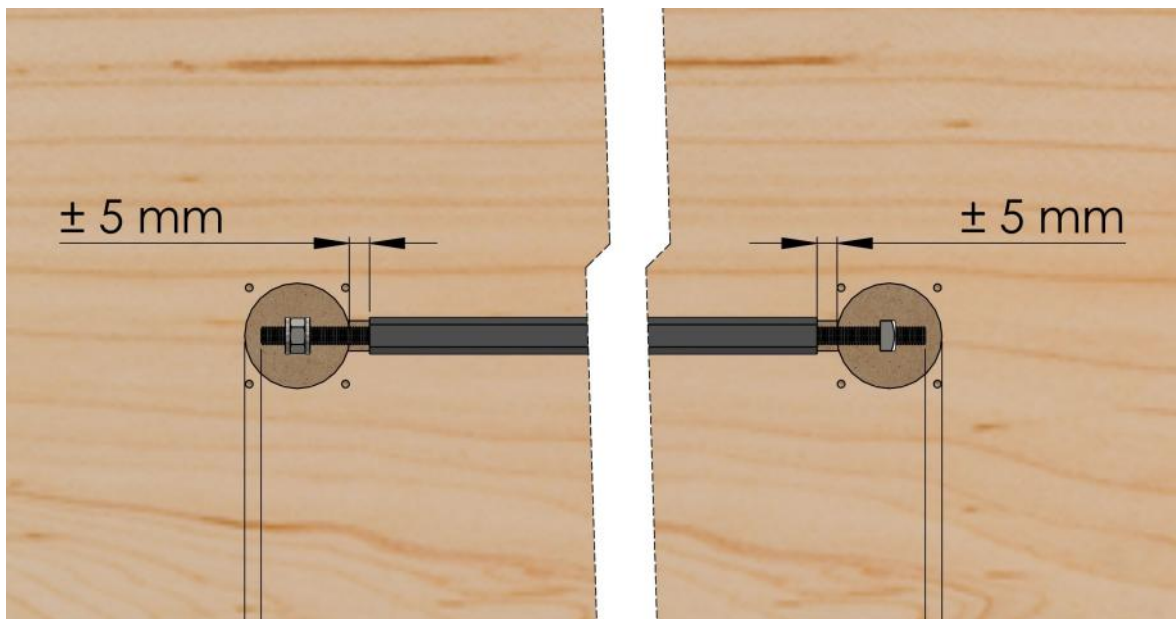

Place the retainers and threaded rod in their respective infreading (see drawings www.Assunta.be).

The tensioner (wide slot) is placed on the hex nut.

Screw the transverse plates over the protective sleeve. Spread them evenly across the width of the panel.

Position the panel straight, tension or loosen the hex nut to get the panel perfectly straight. Place the cover caps over the holders.

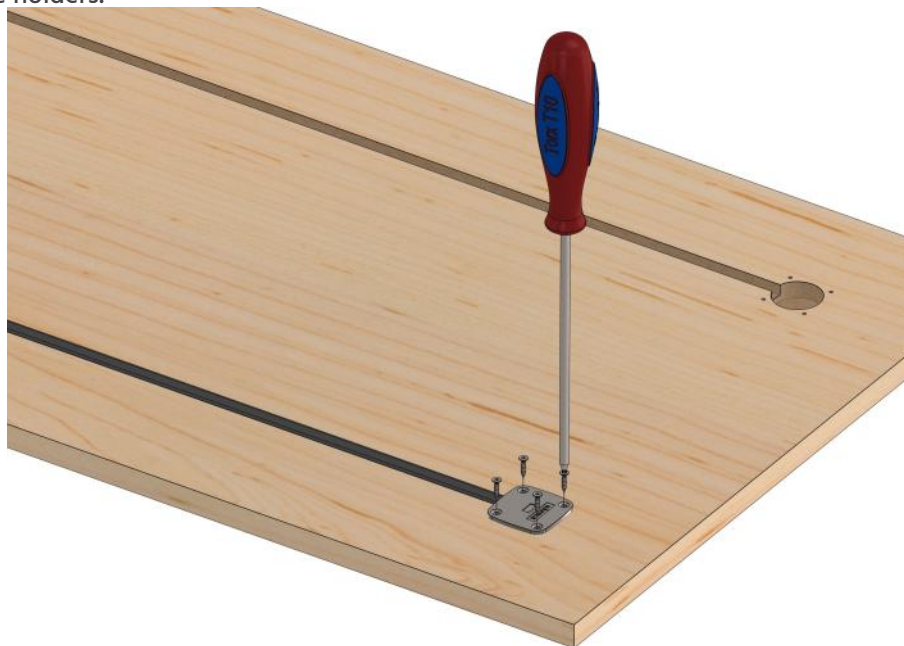

Connection of the relay contact

The relay contact of the control box can also be used to control lighting (or home automation). When the box is fully opened, the contact is switched. The contact is voltage-free. If this is used to control lights, an external power source (max. 6A) must be provided.

