

TECHNICAL

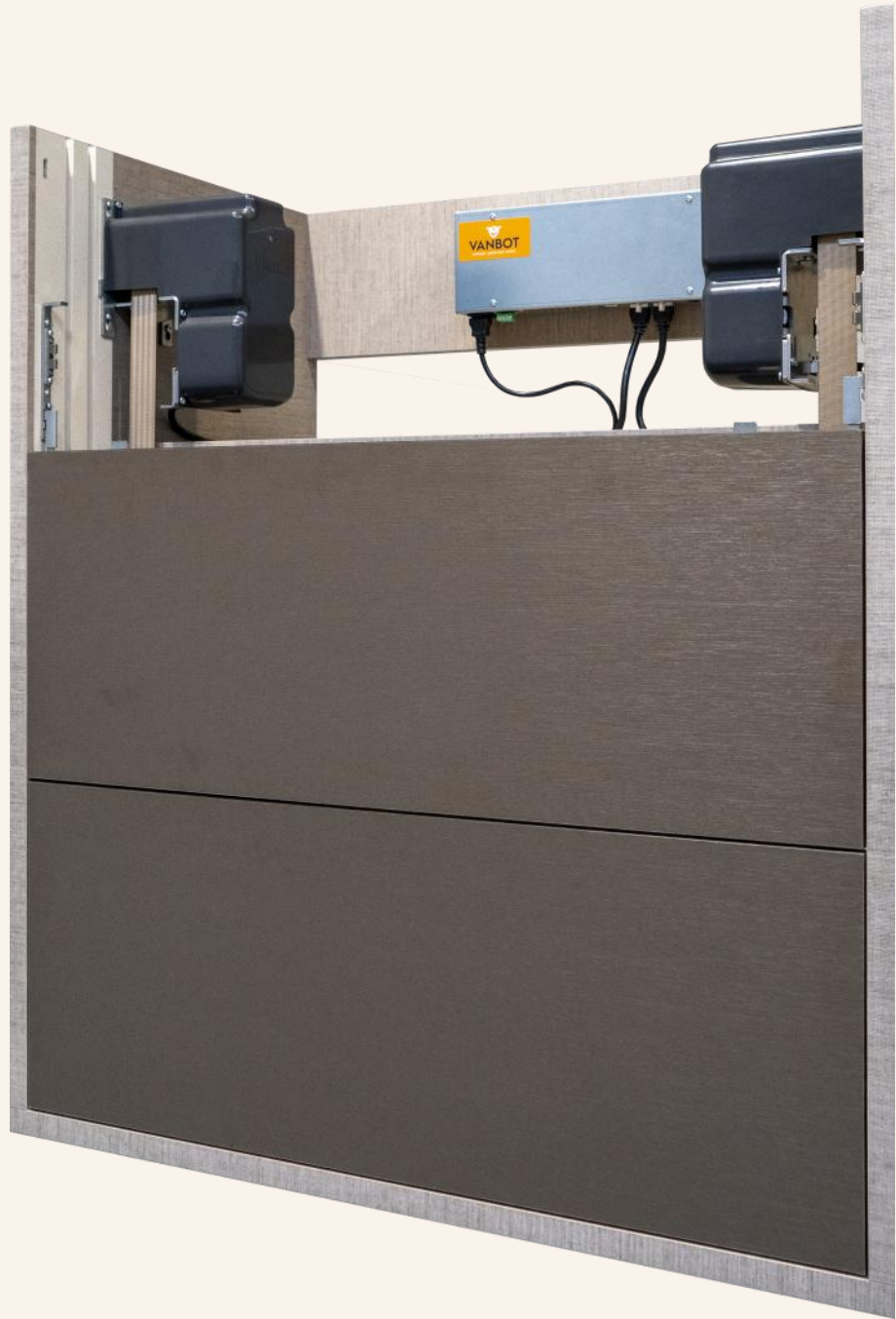

# Dimensions / Definitions

## The body of the cabinet

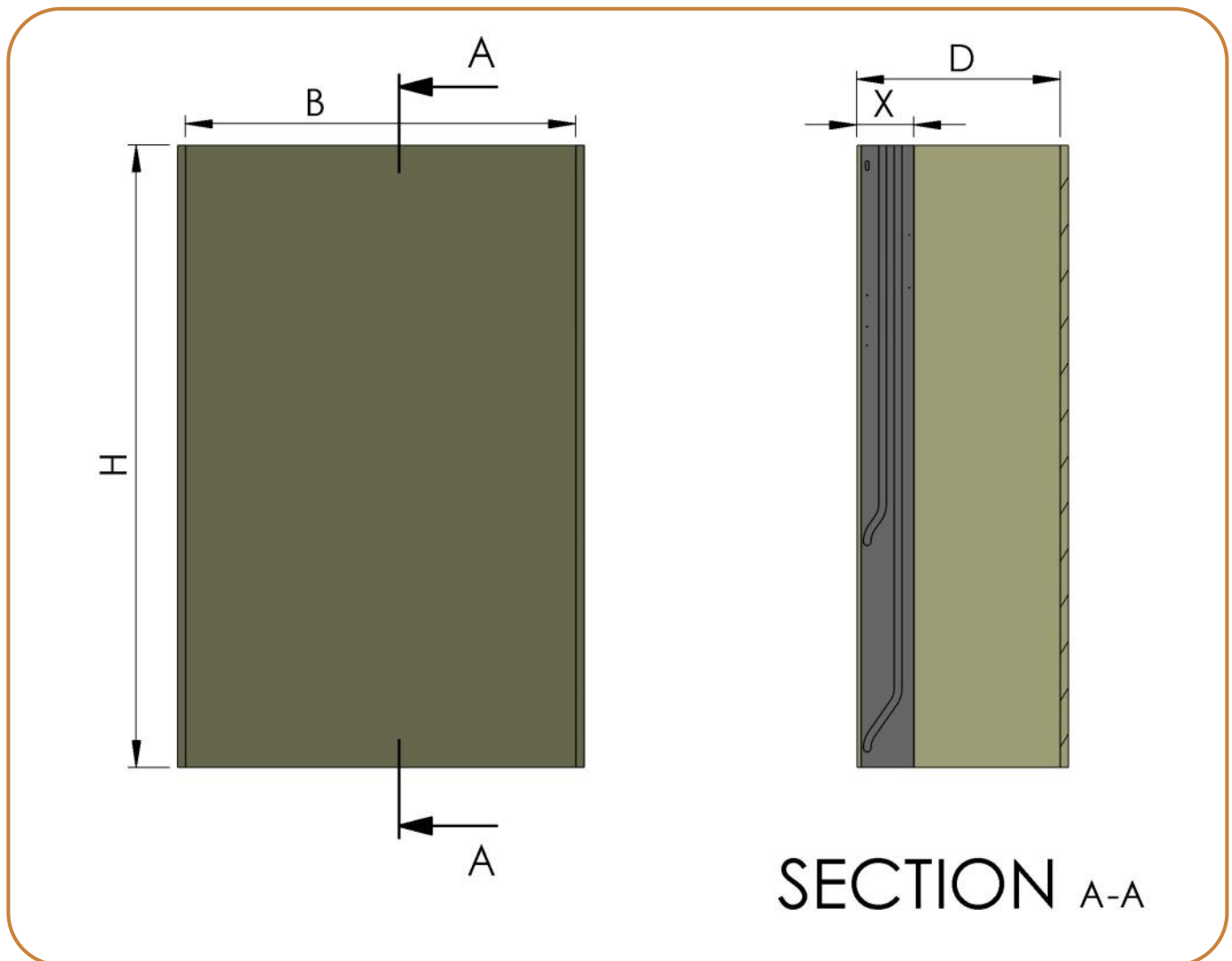

H = Total height of the cabinet (without ceiling)

B = (Span) Width between side walls

X = Space for the guide rail

X = 66 mm + dv (thick fixed panel) + d1 (thick lower panel)  
 + optionally d2 (thick second panel) + 20 mm  
 + optionally d3 (thick third panel) + 20 mm

D = Cabinet depth to back

D – X = Space for shelves

## The panels

### Movable

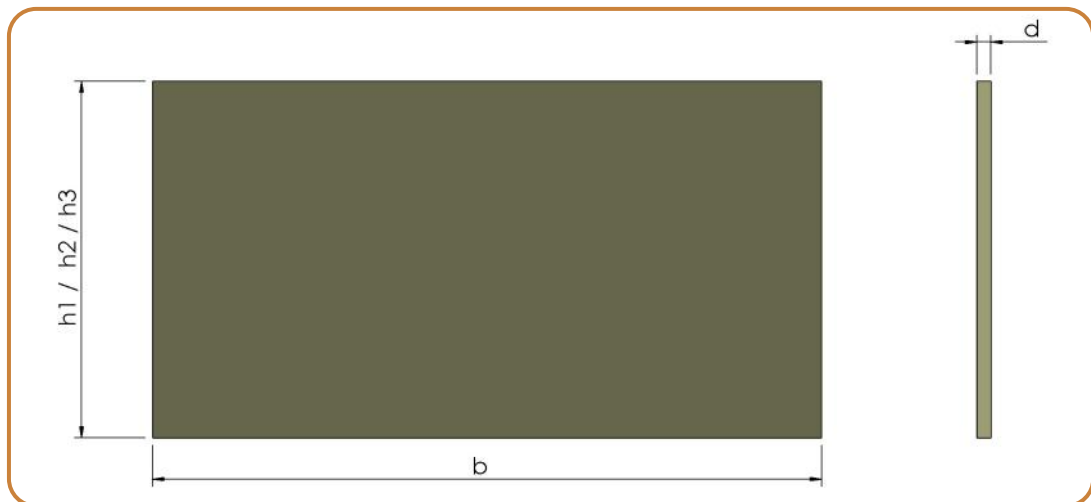

$h1, h2, h3$  = Height movable panel

$b$  = Width movable panel

$d$  = Thick movable paeel

### Vast

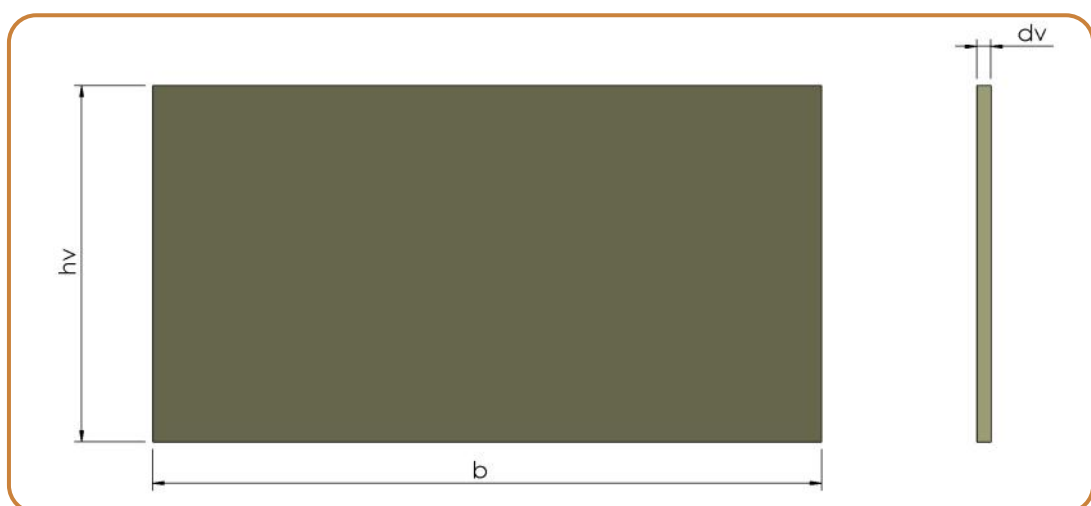

$h_v$  = Height fixed panel

$b$  = Width fixed paneel

$dv$  = Thick fixed paneel

## Clearances

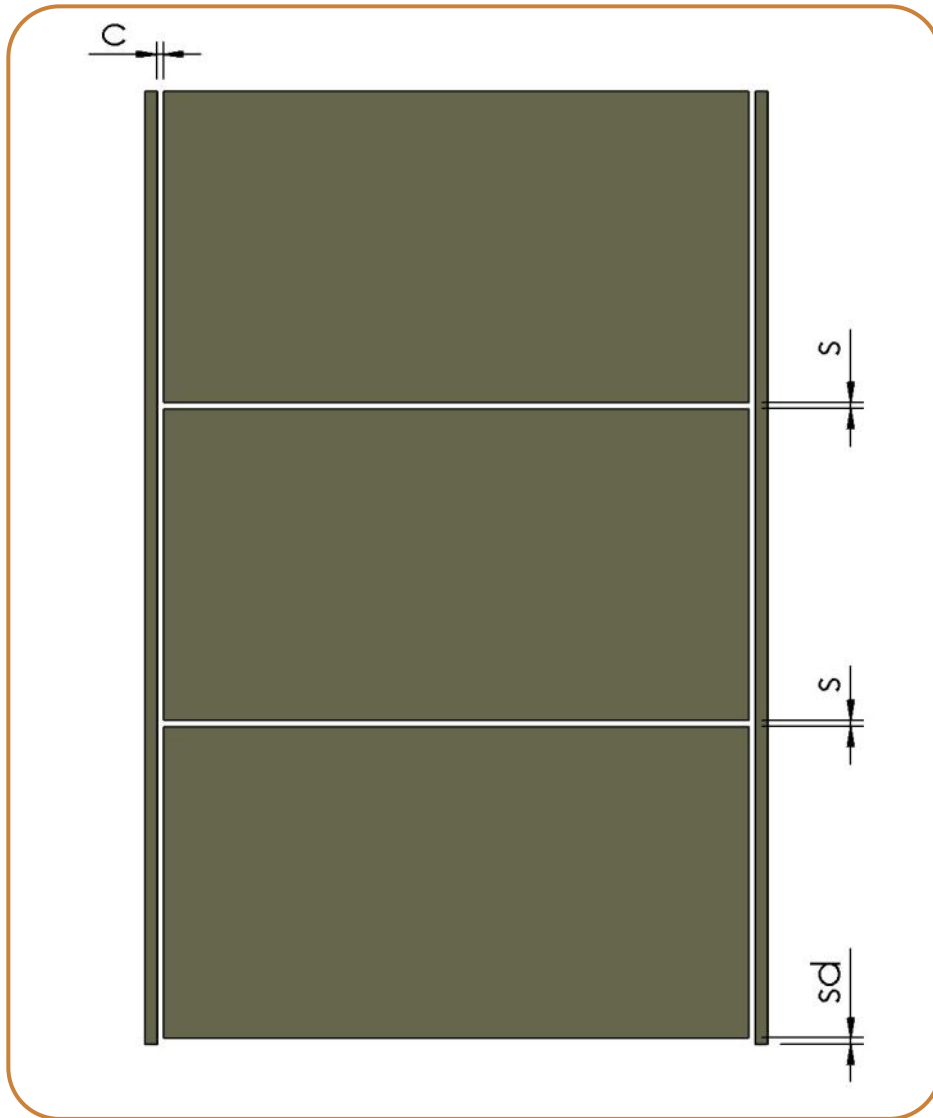

c = Vertical clearance between door panel and side

s = Horizontal clearance between panels

sd = Horizontal clearance between lower panel and bottom

## Inserted panels

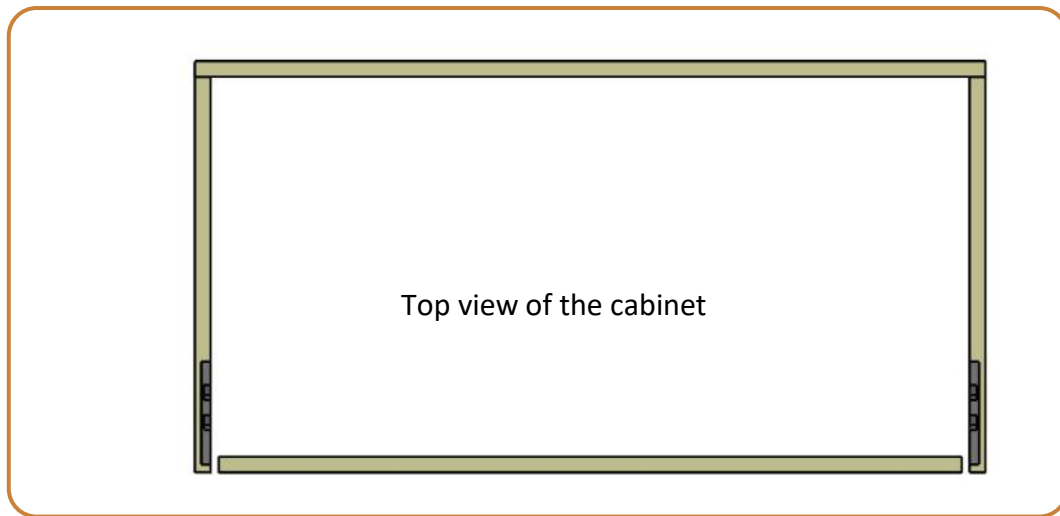

Panels are flush with the front of the corpus. This is the standard arrangement.

## Front covered panels

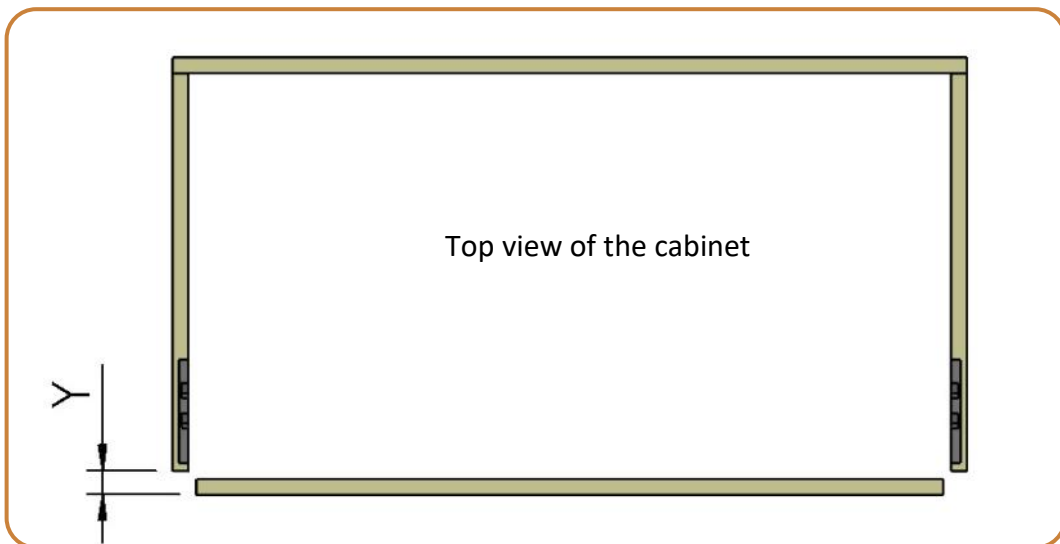

Y = The size of front covered

Panels lie BEFORE the front of the body but still slide in between the side walls. The aim is to level the panels with (hinged) doors of adjacent cabinets.

## Guide rails

### The value T

T = Amount of 'furniture' between front and side guide, maximum panel thickness - 4 mm

X = Total space required for the side rail

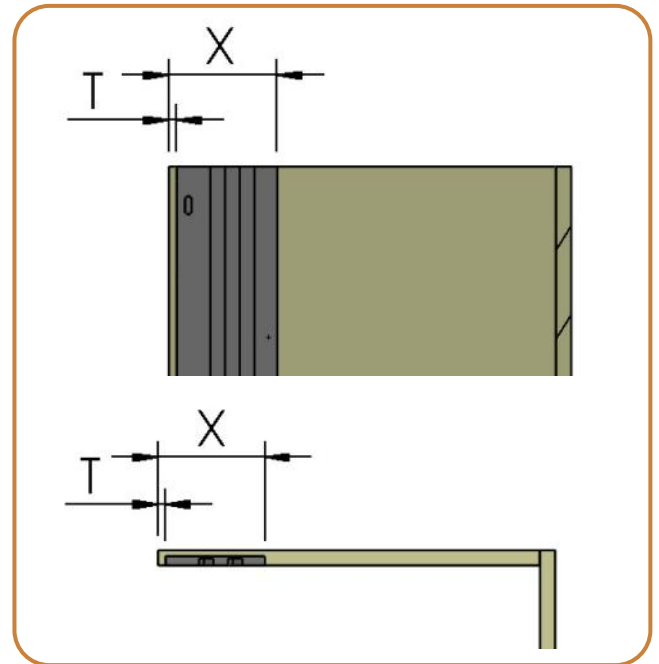

### Dimensions

1 Panel

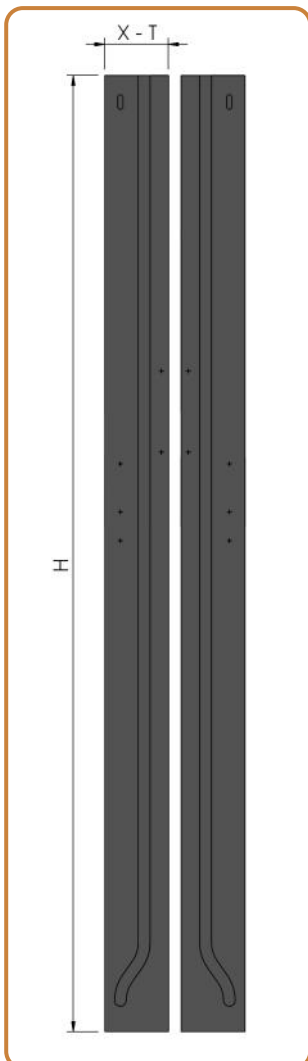

2 Panels

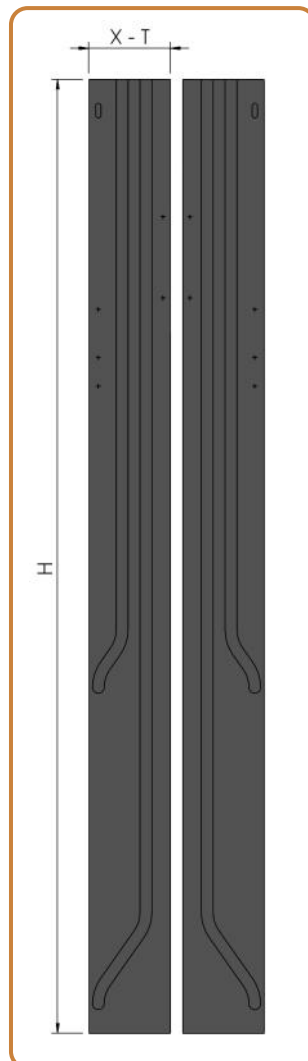

3 Panels

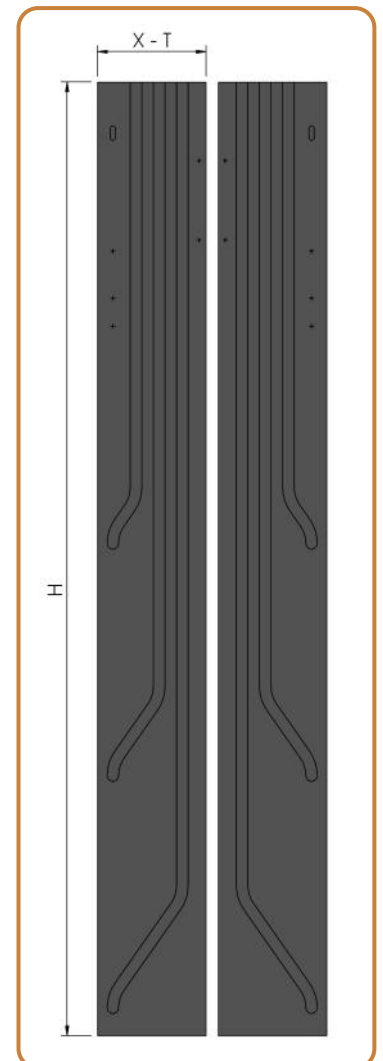

## Frames

All components are housed on frames that are screwed to the back of the panel. Machining is not required. The frames contain the guide wheels, take-away hooks and tilt mechanism.

These are examples of the frames for the lower panel.

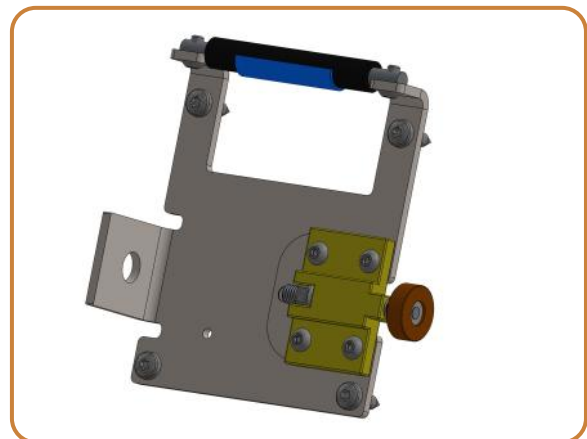
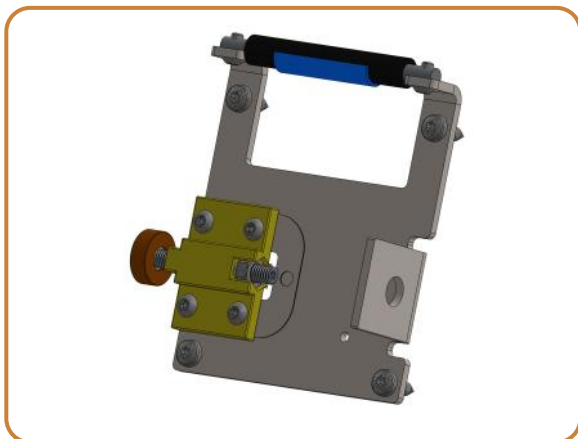
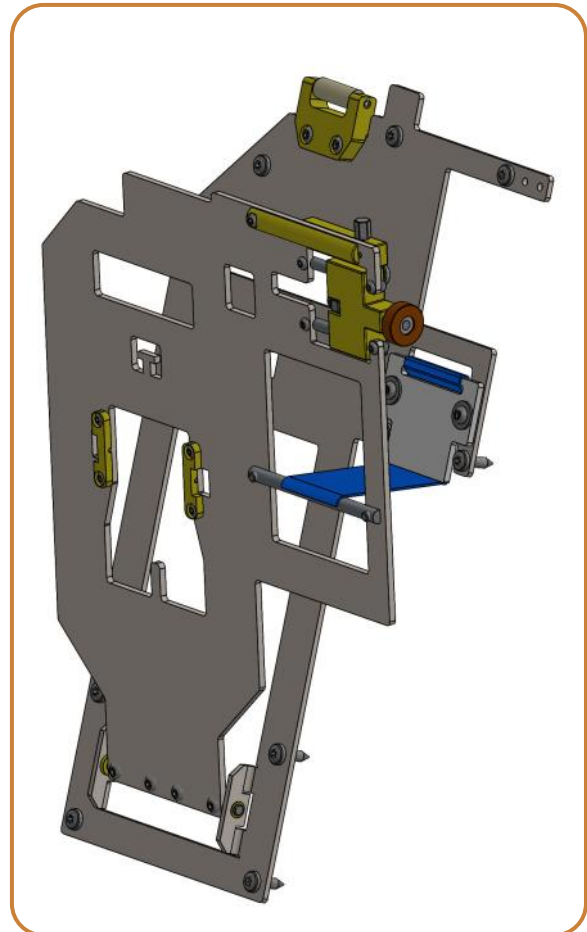
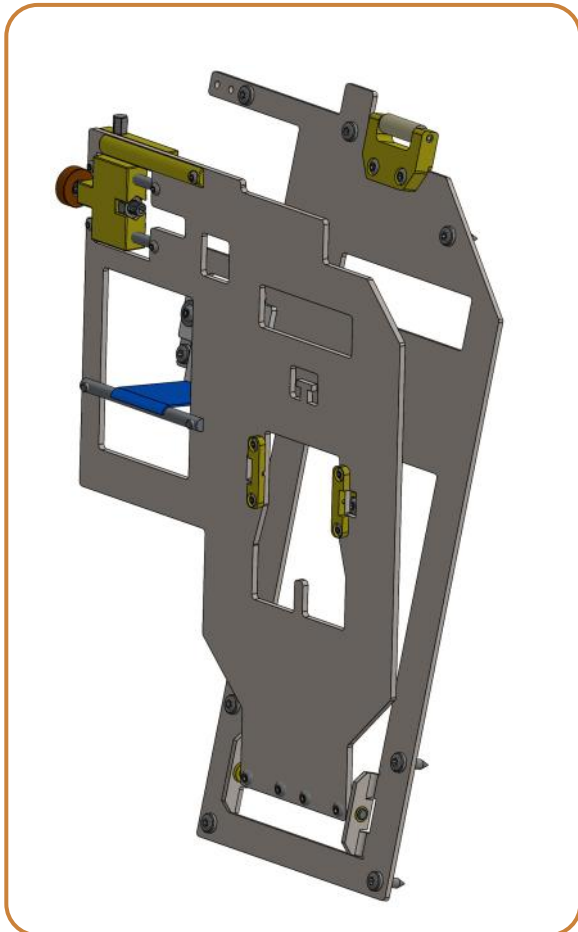

## Lower panel

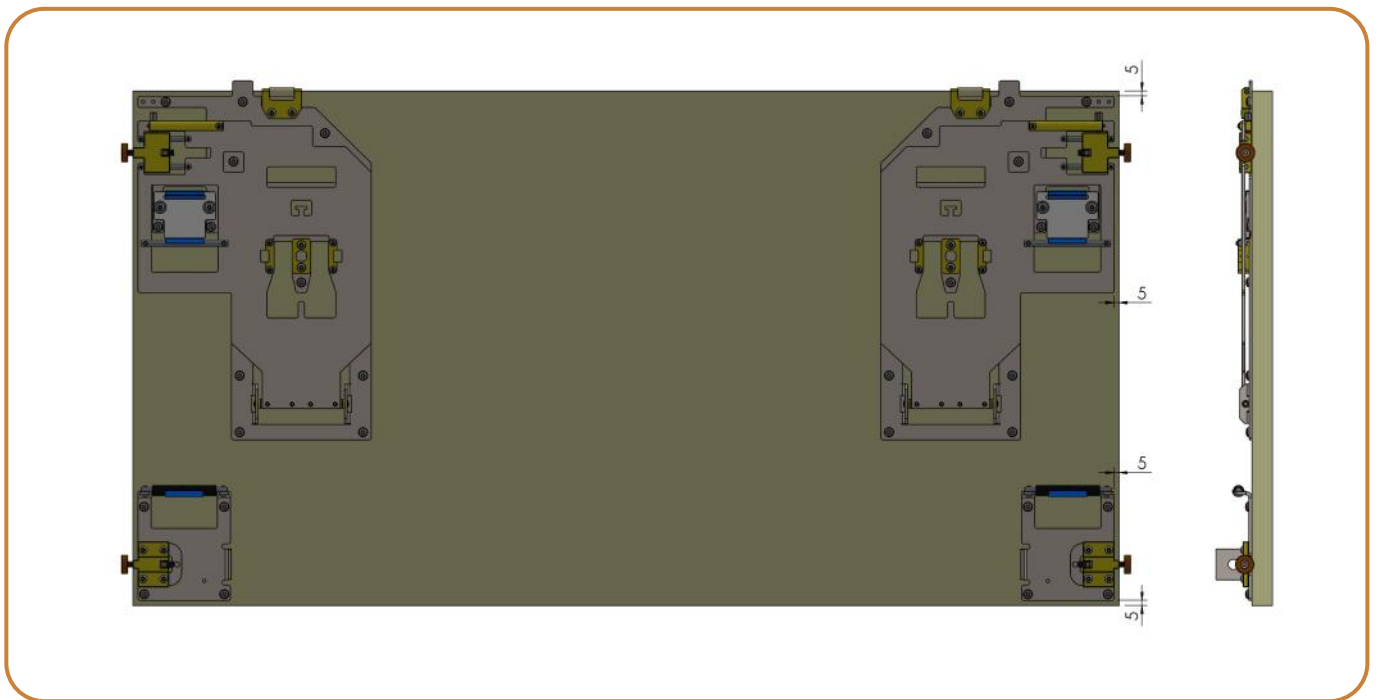

## Second panel (when applicable)

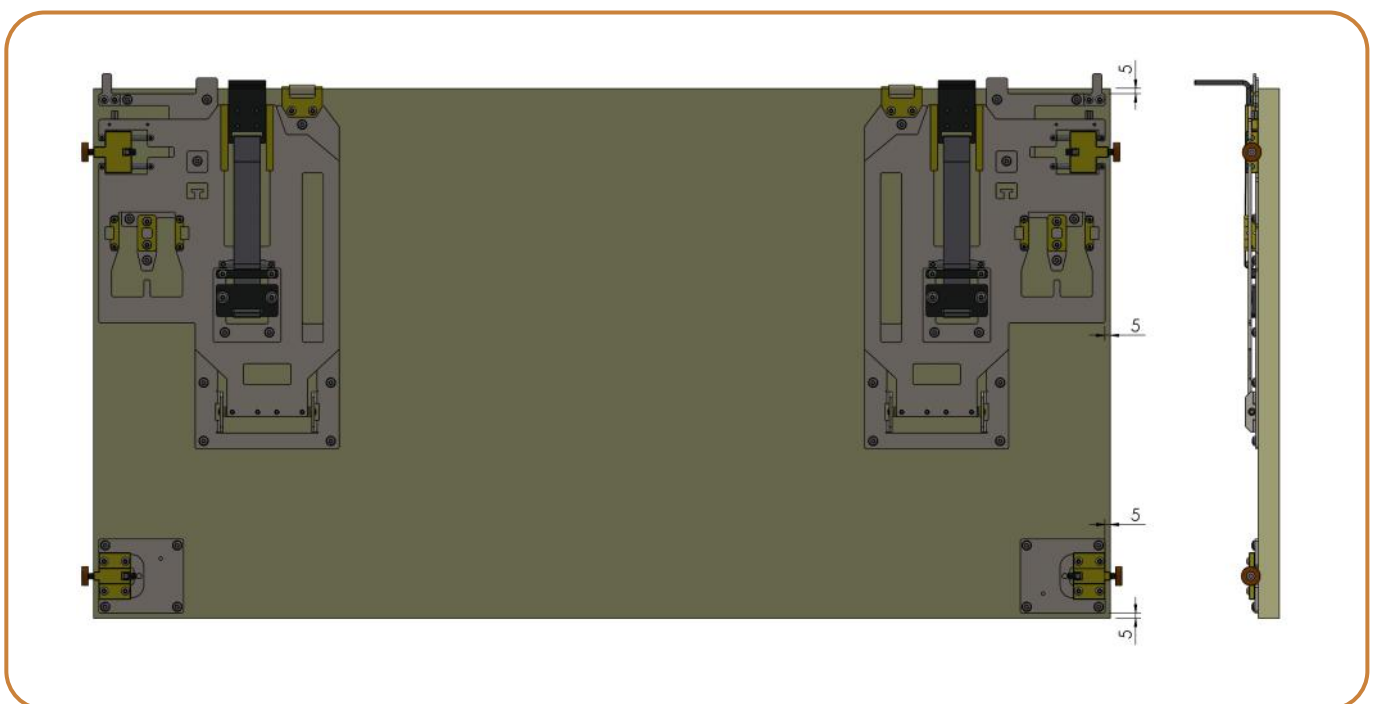

### Third panel (when applicable)

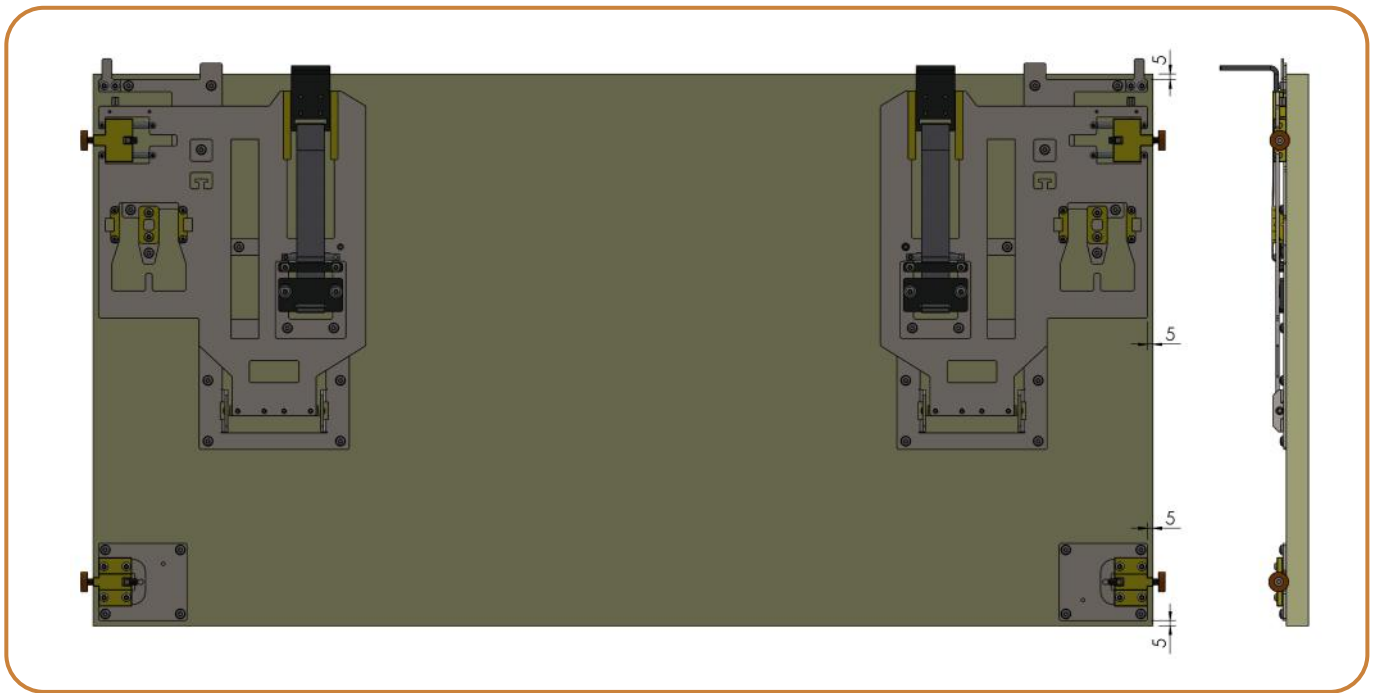

### Fixed panel



## Intermediate plates for front covered panels

For front covered panels, separately available intermediate plates of 6 mm thickness are provided. This makes front covered possible for panels up to 20 mm thick.

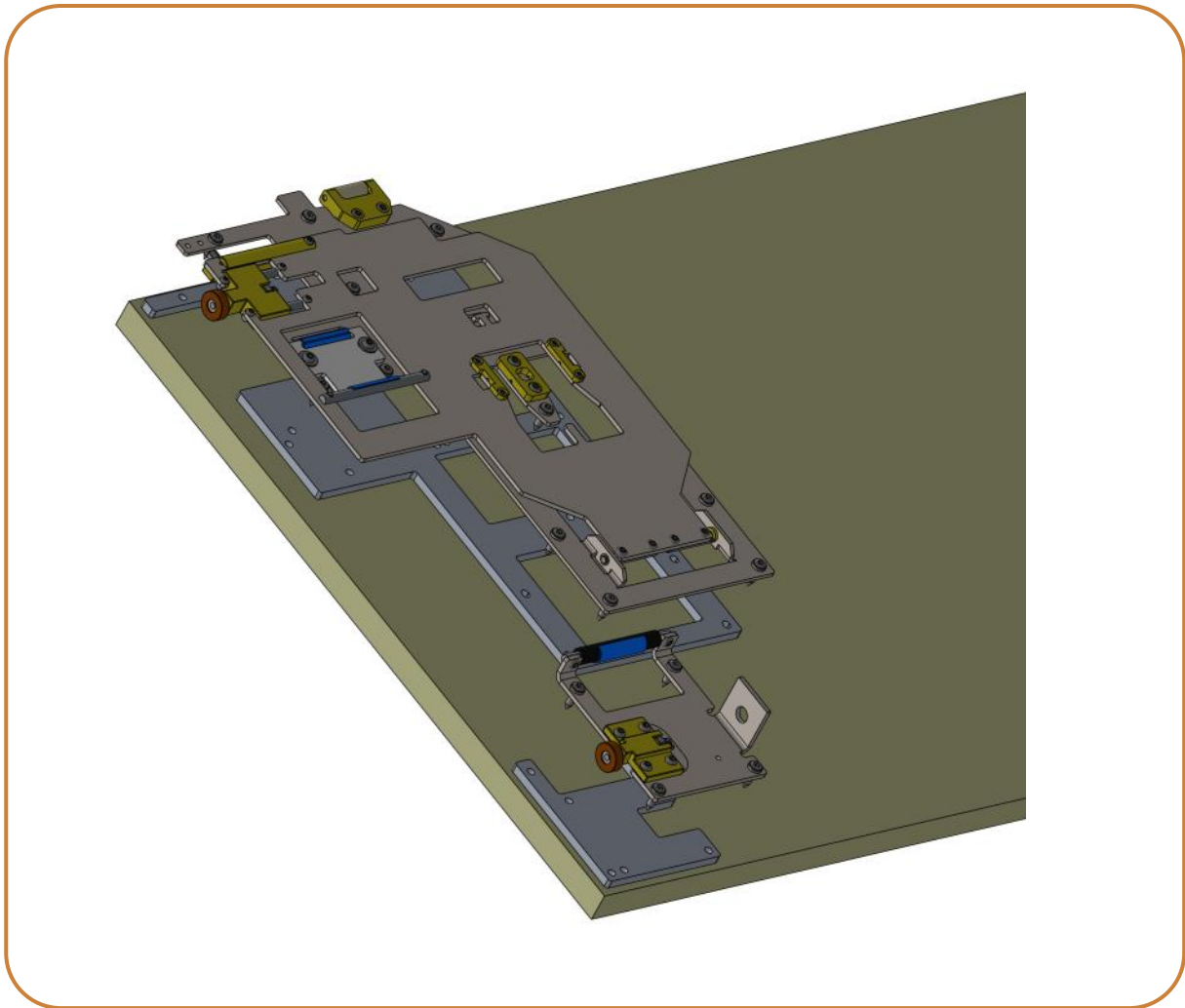

## Drive module

The lifting drives contain the drive motors and belt rollers. They are placed at the top in the lower part of the technical room (behind fixed panel).



## Dimensions



## Assembly

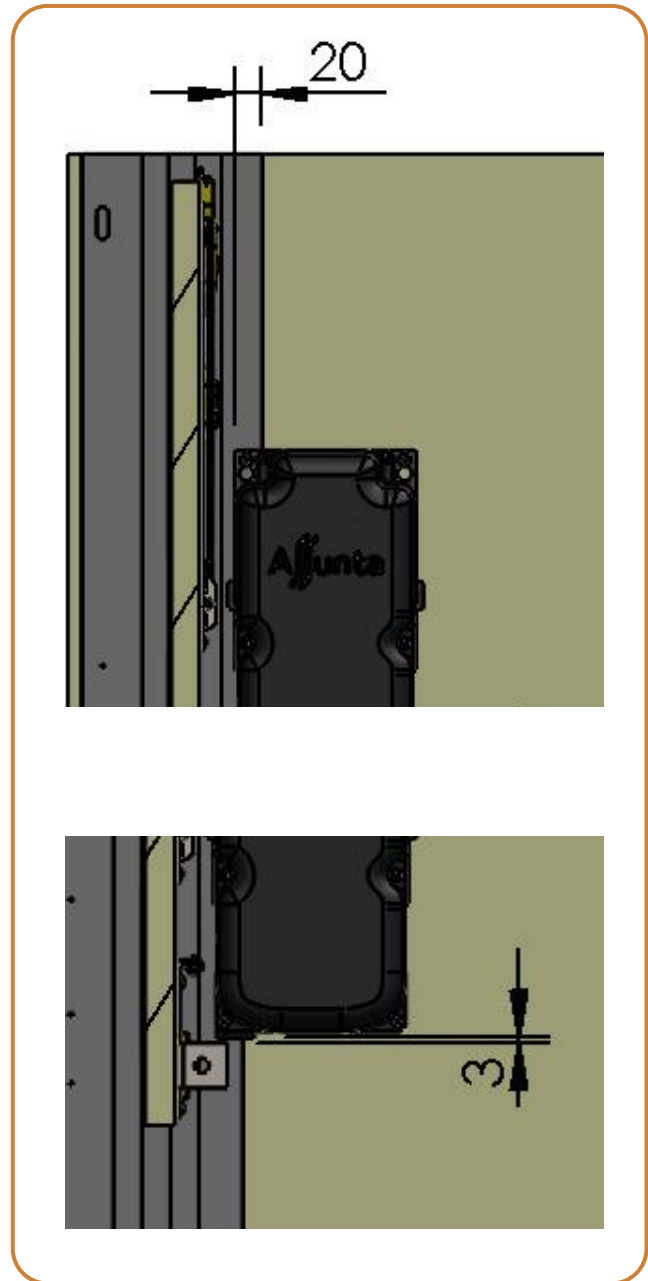
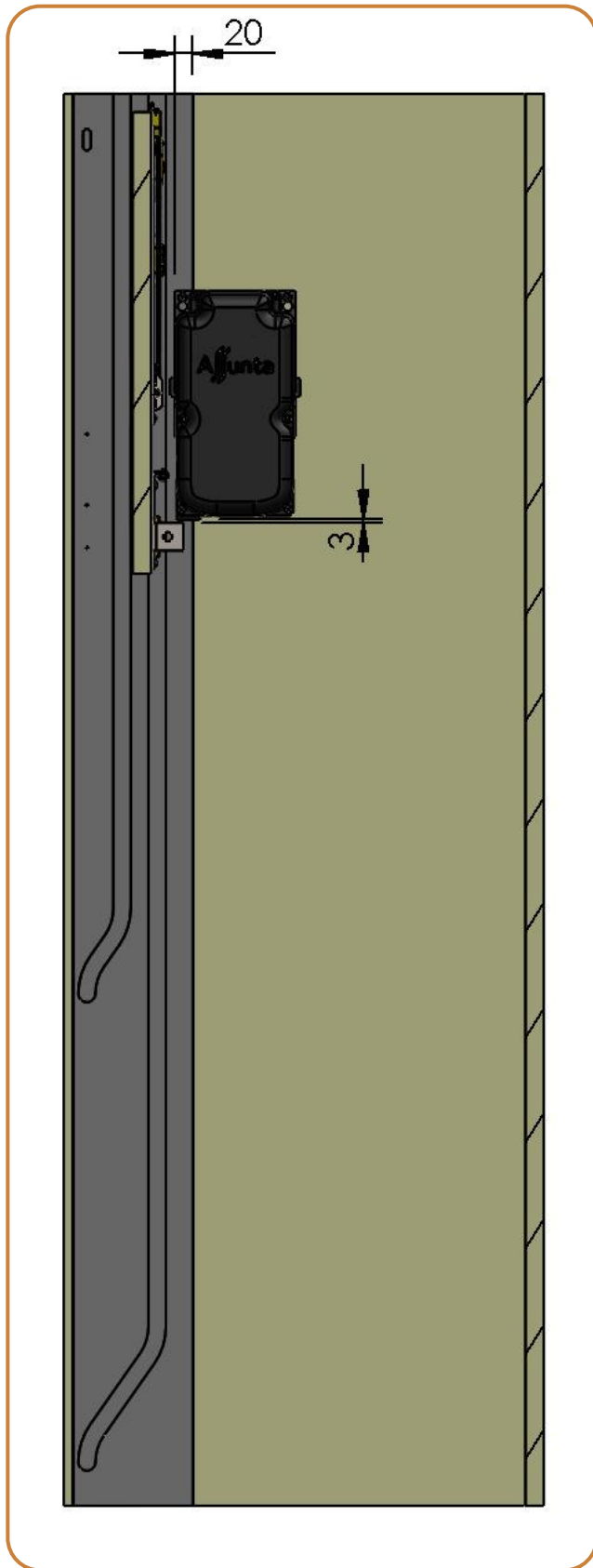

The lift drive is positioned so that the lower panel in the upper open position has its stop 3 mm from the adjustable motor stop. For the exact dimension refer to the drawings at [www.assunta.be](http://www.assunta.be). The front motor attachment points are marked on the side guides.

## The control

### The control box



The control box can be placed in the technical room behind the fixed panel. The 2 m motor cables are sufficiently long for this purpose. It is obviously even more convenient (in case of failure) to mount the control box outside the cabinet but longer motor cables of 4 m must then be provided.

## De bekabeling

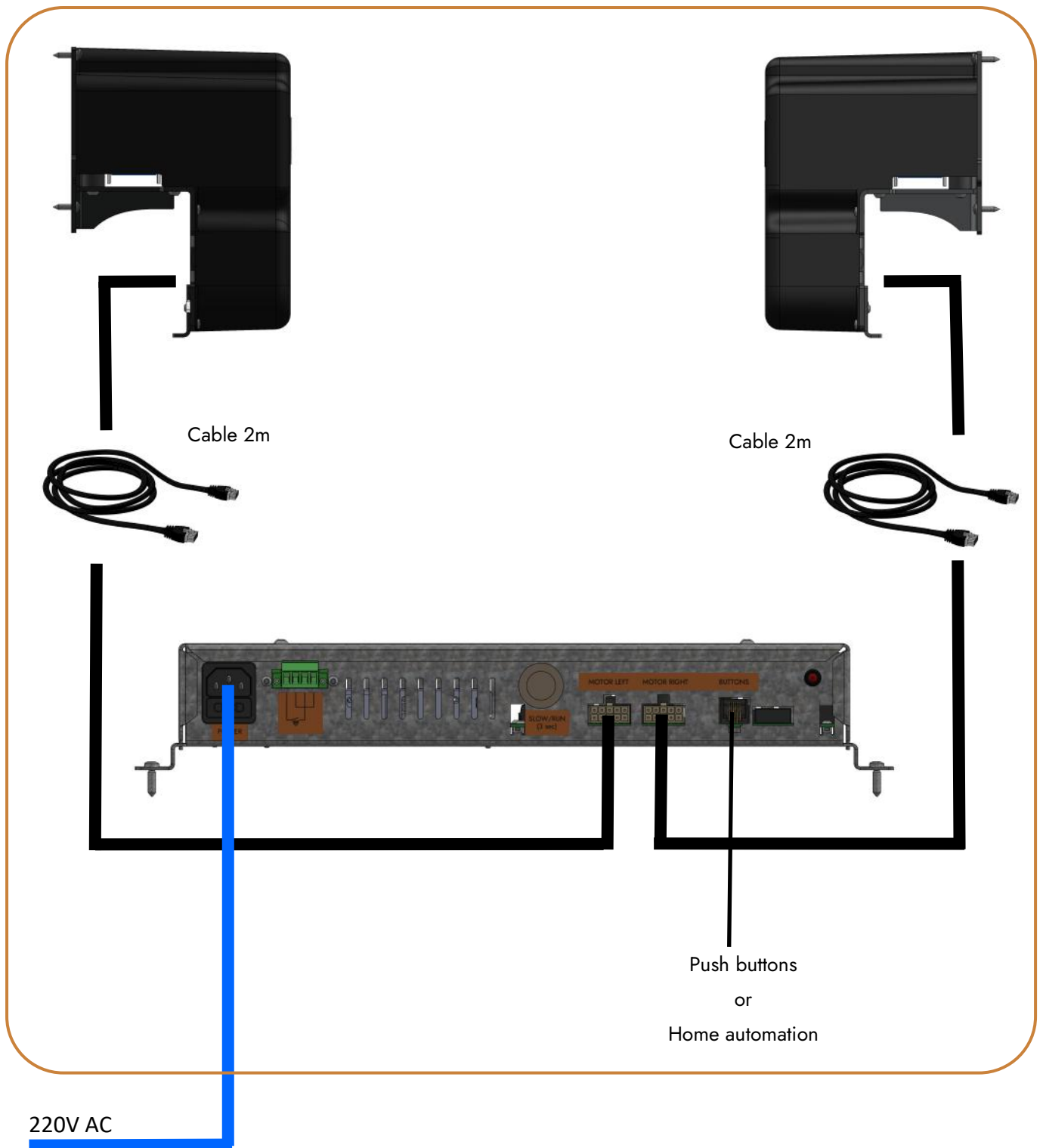

## The software

The control software can be set in different modes.

SLOW: Panels move slowly, is used during installation.

RUN: The final state reached after running initialisation.

More information and guidance can be found in the manual..

## The operation

### Remote control



### Vanbot push buttons

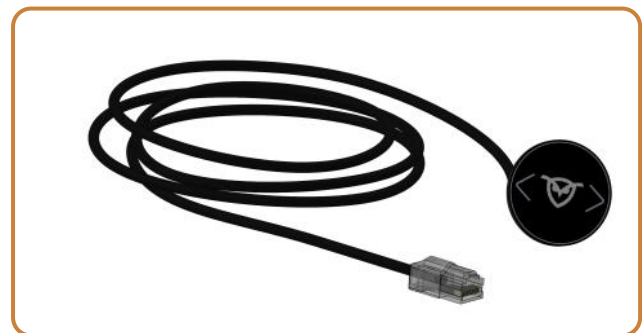
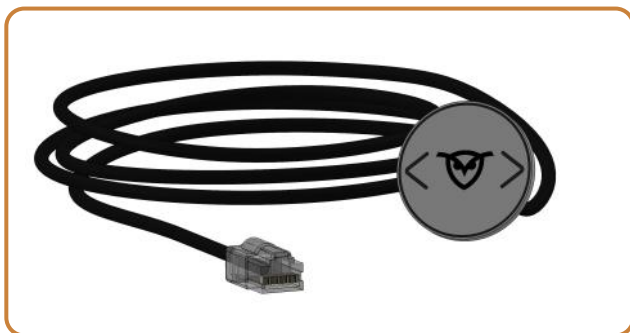

### Own push buttons or home automation

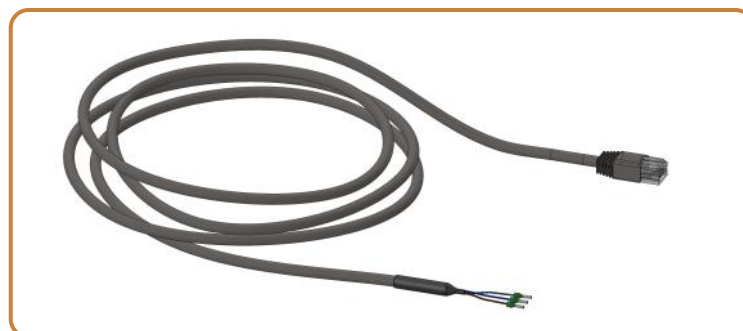

## Notes

Couthoflaan 14-16  
8972 PROVEN—BELGIUM

Contact : Frank Verdonck  
+32 495 53 11 66  
sales@vanbot.be

[vanbot.be](http://vanbot.be)